

ENGLISH

RCA-FSM-18 / RCA-FSM-22 / RCA-FSM-32 / RCA-FSM-42

V1

Ordercode:

D7670 D7671 D7672 D7673

Preface

Thank you for purchasing this Showgear product.

The purpose of this user manual is to provide instructions for the correct and safe use of this product.

Keep the user manual for future reference as it is an integral part of the product. The user manual shall be stored at an easily accessible location.

This user manual contains information concerning:

- Safety instructions
- Installation and operation of the product
- Intended and non-intended use of the product
- Maintenance procedures
- Troubleshooting
- Transport, storage and disposal of the product

Non-observance of the instructions in this user manual may result in serious injuries and damage of property.

©2022 Showgear. All rights reserved.

No part of this document may be copied, published or otherwise reproduced without the prior written consent of Highlite International.

Design and product specifications are subject to change without prior notice.

For the latest version of this document or other language versions, please visit our website www.highlite.com or contact us at service@highlite.com.

Highlite International and its authorized service providers are not liable for any injury, damage, direct or indirect loss, consequential or economic loss or any other loss arising from the use of, or inability to use or reliance on the information contained in this document.

Table of contents

1. Introduction.....	3
1.1. Before Using the Product	3
1.2. Included Parts D7670 / D7671 / D7672 / D7673	4
1.3. Included Items D7670 / D7671 / D7672 / D7673	6
1.4. Intended Use	7
1.5. Text Conventions.....	7
1.6. Symbols and Signal Words	7
1.7. Symbols on the Information Label	7
2. Safety	8
2.1. Warnings and Safety Instructions	8
2.2. Requirements for the User	9
3. Description of the Product.....	10
3.1. Front View	10
3.2. Product Specifications	11
3.3. Dimensions D7670	12
3.4. Dimensions D7671	13
3.5. Dimensions D7672	14
3.6. Dimensions D7673	15
4. Installation	16
4.1. Safety Instructions for Installation	16
4.2. Installation Site Requirements	16
4.3. Tools for Assembling	16
4.4. Assembling the Cabinet.....	17
4.5. Equipment Installation	24
5. Maintenance	26
5.1. Preventive Maintenance	26
5.1.1. Basic Cleaning Instructions.....	26
5.2. Corrective Maintenance	26
6. Deinstallation, Transportation and Storage	27
6.1. Instructions for Deinstallation	27
6.2. Instructions for Transportation	27
6.3. Storage	27
7. Disposal	27

1. Introduction

1.1. Before Using the Product

**Important**

Read and follow the instructions in this user manual before installing, using or servicing this product.

The manufacturer will not accept liability for any resulting damages caused by the non-observance of this manual.

After unpacking, check the contents of the box. If any parts are missing or damaged, contact your Highlite International dealer.

Your shipment includes:

- Showgear RCA-FSM-18 / RCA-FSM-22 / RCA-FSM-32 / RCA-FSM-42
- Parts, as shown on page 4 and 5
- Screws, as shown on page 6
- User manual

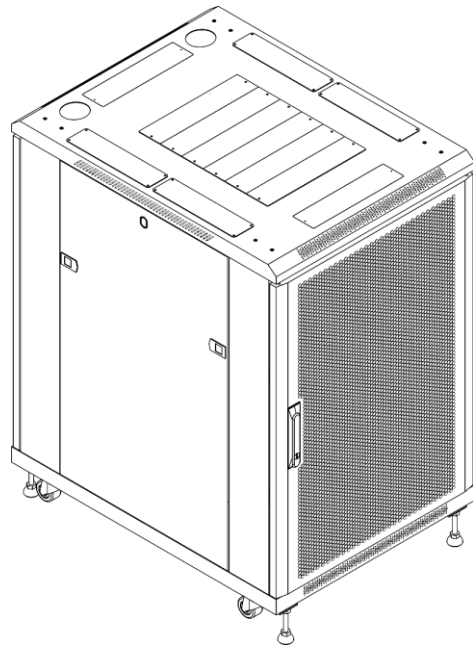

Fig. 01

1.2. Included Parts D7670 / D7671 / D7672 / D7673

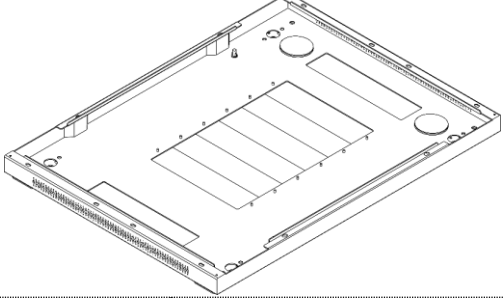
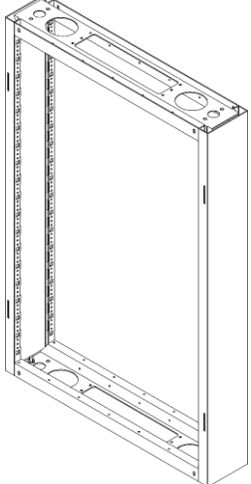
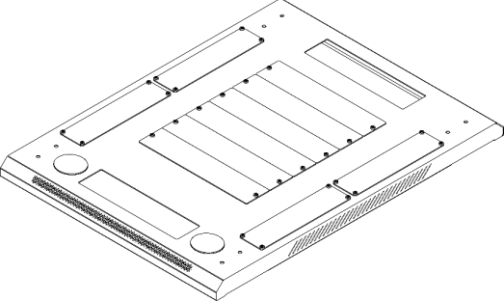
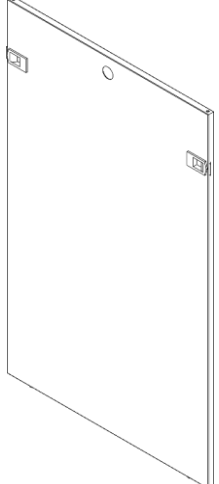
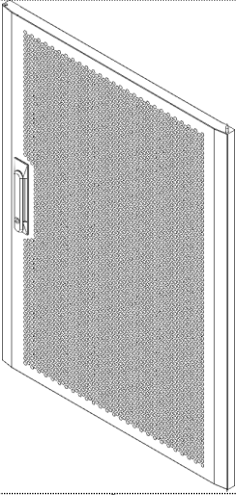

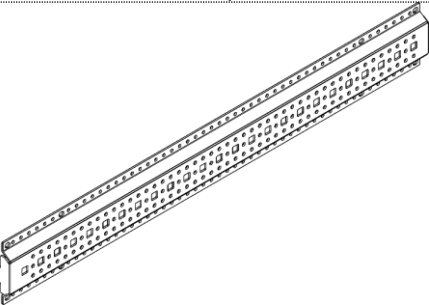
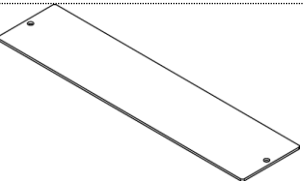
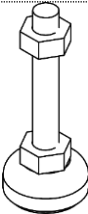
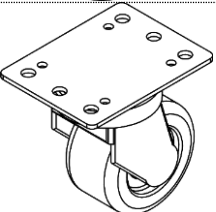
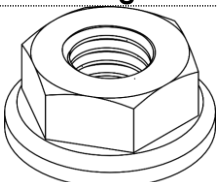
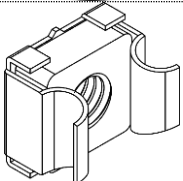
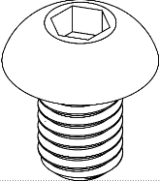
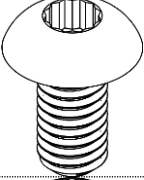
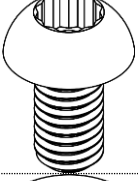
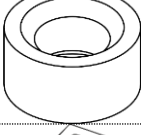
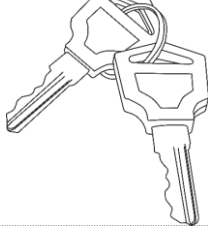
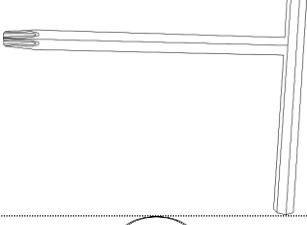
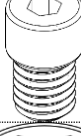

Image	Item	Name	D7670, D7671, D7672, D7673
	A	Bottom plate	1 x
	B	Frame	2 x
	C	Top plate	1 x
	D	Side panel	2 x

Image	Item	Name	D7670, D7671, D7672, D7673
	E	Mesh door	2 x
	F	Vertical bracket	4 x
	G	Horizontal bracket	4x (D7670 / D7671 / D7672) 6x (D7673)
	H	Metal plate	2 x
	I	Adjustable foot	4 x
	J	Wheel	4 x

1.3. Included Items D7670 / D7671 / D7672 / D7673

Image	Item	Name	D7670	D7671	D7672	D7673
	K	Nut (M6) (wrench 13)	16 x	16 x	16 x	16 x
	L	Cage nut (M6)	20 x	20 x	20 x	40 x
	M	Screw 8 x 12 mm (hex 5)	16 x	16 x	16 x	16 x
	N	Screw 6 x 12 mm (T20)	20 x	20 x	20 x	40 x
	O	Screw 5,5 x 10 mm (T20)	100 x	100 x	104 x	120 x
	P	Ring	2 x	2 x	2 x	2 x
	Q	Set of keys	2 x	2 x	2 x	2 x
	R	Hex key (T20)	1 x	1 x	1 x	1 x
	S	Side panel screw M5 x 6 mm	4 x	4 x	4 x	4 x
	T	Self-tapping screw M4 x 8 mm	8 x	8 x	8 x	8 x

1.4. Intended Use

This product is intended for professional use as a server rack cabinet in theaters, entertainment facilities, public venues, and similar. It is suitable only for indoor use. This product is not suitable for households.

Any other use, not mentioned under intended use, is regarded as non-intended and incorrect use.

1.5. Text Conventions

Throughout the user manual the following text conventions are used:

- References: References to chapters and parts of the product are in bold lettering, for example: "Refer to **2. Safety**", "turn the **adjustment screw (02)**"
- 0–255: Defines a range of values
- Notes: **Note:** (in bold lettering) is followed by useful information or tips

1.6. Symbols and Signal Words

Safety notes and warnings are indicated throughout the user manual by safety signs.

Always follow the instructions provided in this user manual.



DANGER

Indicates an imminently hazardous situation which, if not avoided, will result in death or serious injury.



WARNING

Indicates a potentially hazardous situation which, if not avoided, could result in death or serious injury.



CAUTION

Indicates a potentially hazardous situation, which, if not avoided, may result in minor or moderate injury.



Attention

Indicates important information for the correct operation and use of the product.



Attention

Heavy object



Important

Read and observe the instructions in this document.

1.7. Symbols on the Information Label

This product is provided with an information label. The information label is located on the backside of the product.

The information label contains the following symbols:



This product is designed for indoor use.



Read and follow the instructions in the user manual before installing, operating or servicing the product.

2. Safety



Important

Read and follow the instructions in this user manual before installing, using or servicing this product.

The manufacturer will not accept liability for any resulting damages caused by the non-observance of this manual.

2.1. Warnings and Safety Instructions



DANGER

Danger for children

This product is not suitable for installation in locations where children are likely to be present.

- Do not leave various parts of the packaging (plastic bags, polystyrene foam, nails, etc.) within children's reach. Packaging material is a potential source of danger for children.



WARNING

Stability hazard

This product may fall or tip over, causing serious personal injury and material damage.

- Do not push the cabinet from the side panels to move it.
- When moving the cabinet on the wheels, push it from behind. Do not pull the cabinet towards you.
- Make sure that the cabinet is fully assembled and secured before you install equipment in the cabinet.
- Do not exceed the maximum load capacity of the cabinet. Make sure that the cabinet can support the total weight of all equipment installed.
- When you install equipment in the cabinet, start with the bottom of the cabinet. Put heavier equipment at the bottom of the cabinet.



Attention

Heavy object

This product is heavy. Minimum two persons are necessary to assemble or to move the cabinet.



Attention

General safety

- Do not put any object on the cabinet.
- Do not stack the cabinets.
- Do not use the wheels to support the cabinet or to relocate the cabinet. The wheels are designed to move the cabinet only over short distances.
- Make sure that there is sufficient space for ventilation around the cabinet.
- Do not block or cover the ventilation openings of the cabinet. Do not insert objects into the ventilation openings of the cabinet.
- Keep the cabinet away from moisture, temperature extremes, flammable liquids and gasses, conductive contaminants, dust and direct sunlight.

**Attention****For professional use only****This product shall be used only for the purposes it is designed for.**

This product is intended for professional use as a server rack cabinet in theaters, entertainment facilities, public venues, and similar. Any incorrect use may lead to hazardous situations and result in injuries and material damage.

- This product is not suitable for households.
- This product does not contain user-serviceable parts. Unauthorized modifications to the product will render the warranty void. Such modifications may result in injuries and material damage.

**Attention****Do not expose the product to conditions that exceed the rated IP class conditions.**

This product is IP20 rated. IP (Ingress Protection) 20 class provides protection against solid objects greater than 12 mm, such as fingers, and no protection against harmful ingress of water.

2.2. Requirements for the User

This product may be used by ordinary persons. Assembling, installation, and maintenance shall be carried out only by instructed or skilled persons. Contact your Highlite International dealer for more information.

Instructed persons have been instructed and trained by a skilled person, or are supervised by a skilled person, for specific tasks and work activities associated with the installation, service and maintenance of this product, so that they can identify risks and take precautions to avoid them.

Skilled persons have training or experience, which enables them to recognize risks and to avoid hazards associated with the installation, service and maintenance of this product.

Ordinary persons are all persons other than instructed persons and skilled persons. Ordinary persons include not only users of the product but also any other persons that may have access to the product or who may be in the vicinity of the product.

3. Description of the Product

The Showgear RCA-FSM-18 / RCA-FSM-22 / RCA-FSM-32 / RCA-FSM-42 is a lockable 19-inch network cabinet with an 18 rack / 22 rack / 32 rack / 42 rack unit height. It comes with both swivel wheels and rubber feet. This network cabinet can be opened at every side since it has two detachable side panels and a mesh door at the back and front of the cabinet. This makes it easy to install and install equipment.

The RCA-FSM-18 / RCA-FSM-22 / RCA-FSM-32 / RCA-FSM-42 has a black, metal housing and comes with a dedicated 19-inch rack installation kit, bolt & washer, cage nut, keys and screws.

3.1. Front View

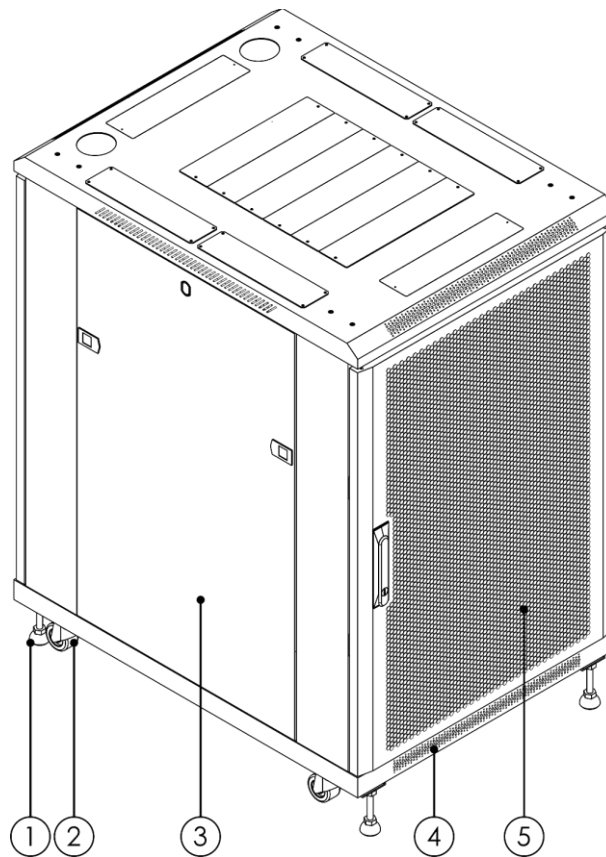

Fig. 02

- 01) M12 Adjustable feet
- 02) 4 x Wheel
- 03) Side panel with locking mechanism
- 04) Ventilation openings
- 05) 2 x Mesh door with a key lock

3.2. Product Specifications

Model:	RCA-FSM-18	RCA-FSM-22	RCA-FSM-32	RCA-FSM-42
--------	------------	------------	------------	------------

Physical:				
Rack units:	18 U	22 U	32 U	42 U
Inner rack dimensions:	19" x 18 U (LxH)	19" x 22 U (LxH)	19" x 32 U (LxH)	19" x 42 U (LxH)
Dimensions:	827 x 604 x 1003 mm (LxWxH)	827 x 604 x 1177 mm (LxWxH)	827 x 604 x 1622 mm (LxWxH)	827 x 604 x 2067 mm (LxWxH)
Weight:	61 kg	70 kg	90 kg	112 kg
Maximum Load	750 kg			

Product Properties:	
Housing:	Metal
Color:	Black
IP rating:	IP20
Rack Rail Type:	Fixed
Wheels:	4 x 40 mm swivel wheels without brake
Feet:	Adjustable feet with rubber feet
Door:	2 x Mesh door with a key lock
Side panel:	2 x Detachable side panel
Keys:	2 x Set of 2 keys

3.3. Dimensions D7670

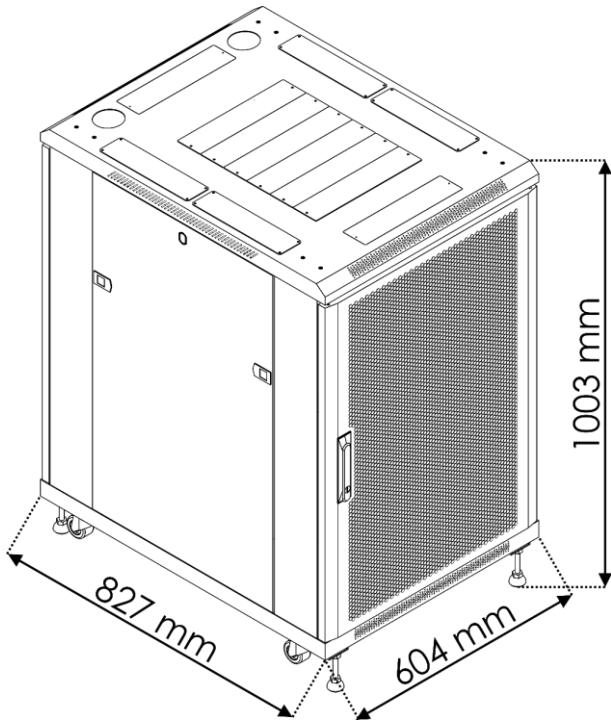

Fig. 03

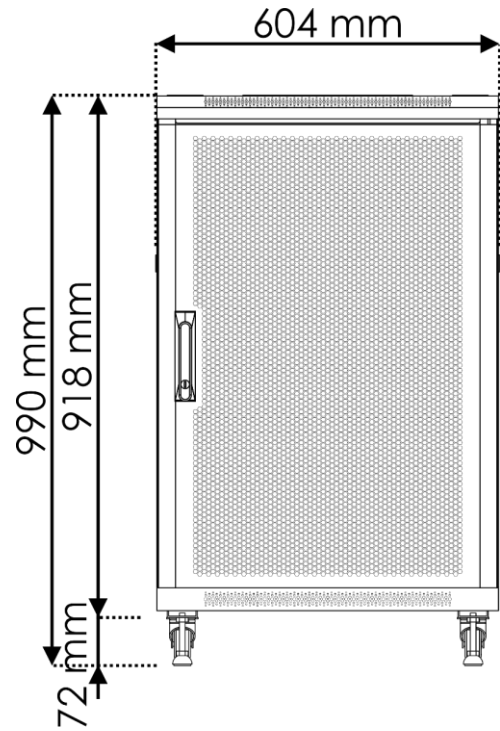

Fig. 04

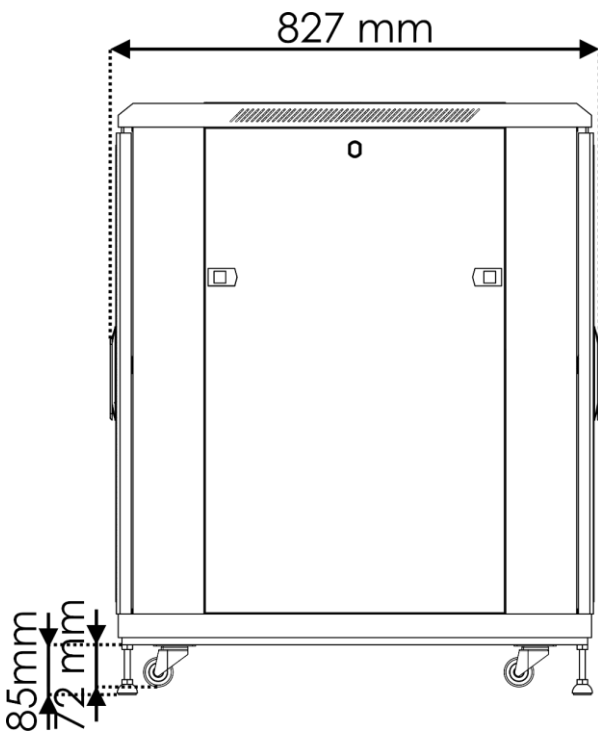

Fig. 05

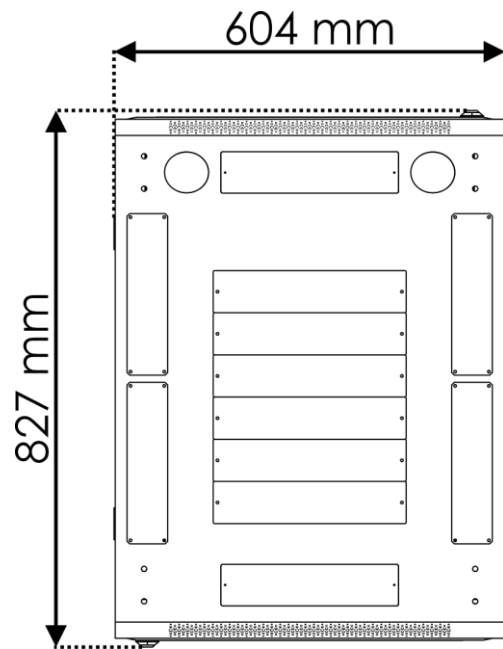

Fig. 06

3.4. Dimensions D7671

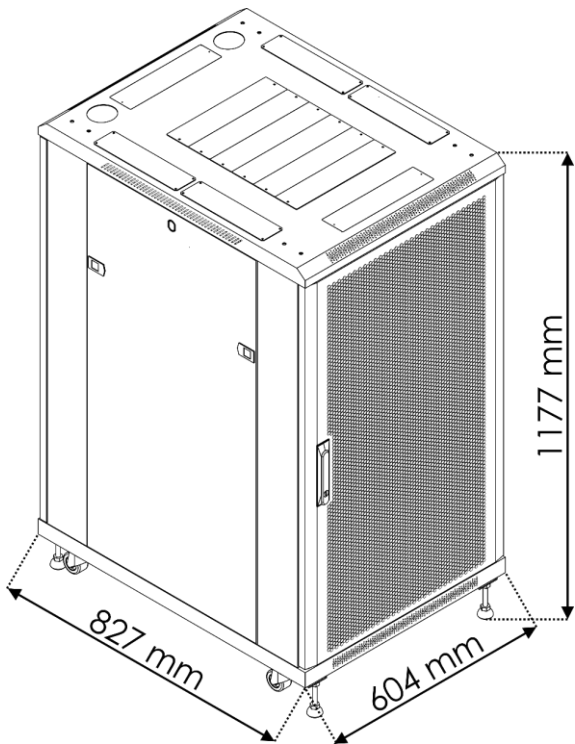

Fig. 07

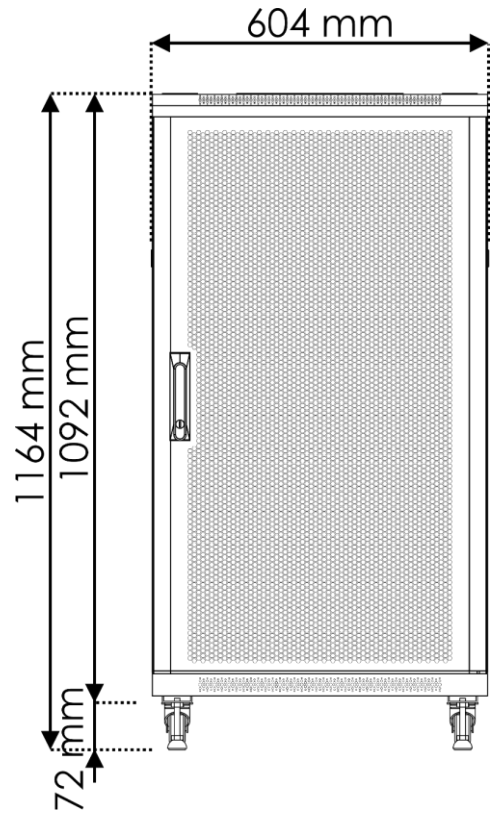

Fig. 08

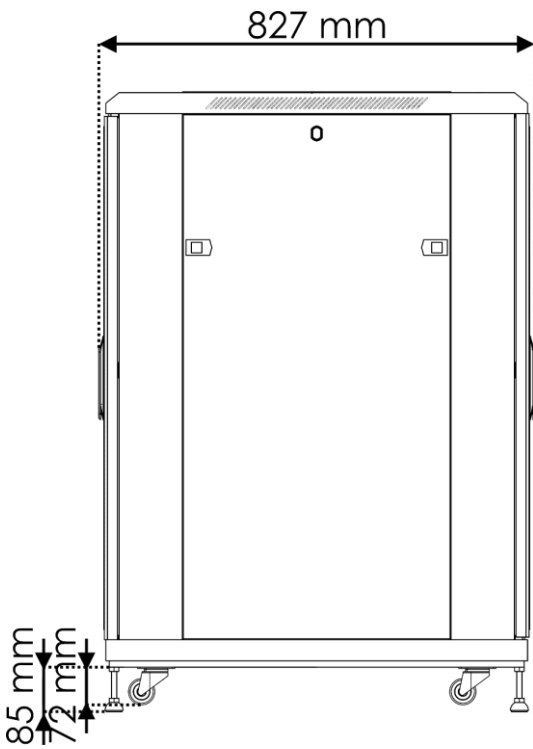

Fig. 09

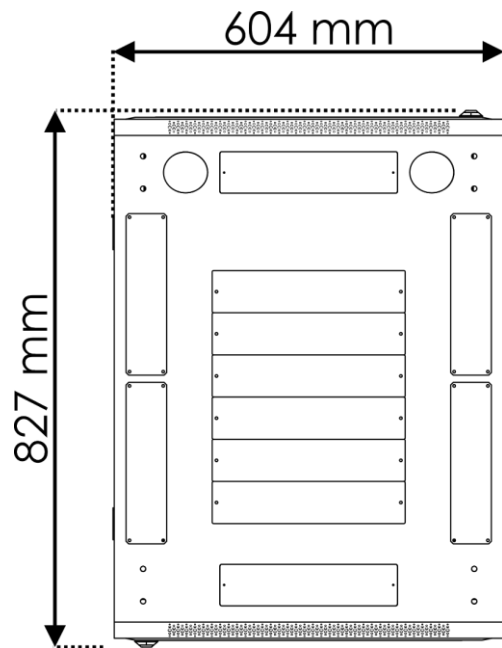

Fig. 10

3.5. Dimensions D7672

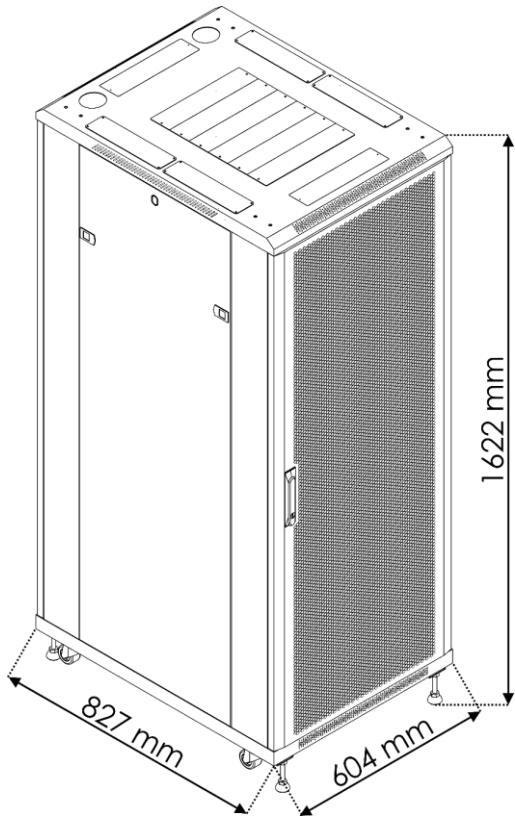

Fig. 11

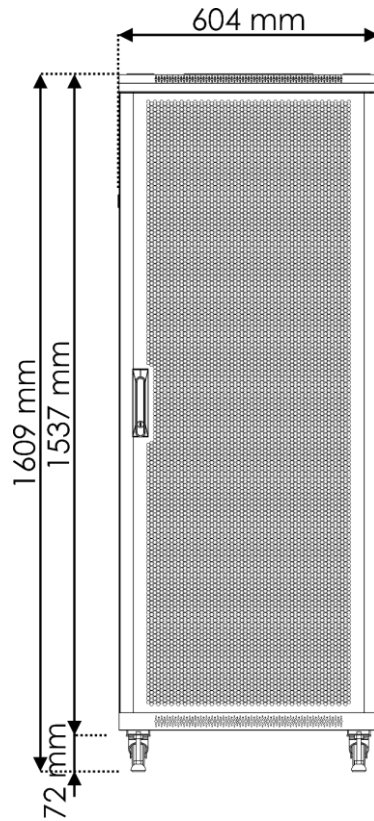

Fig. 12

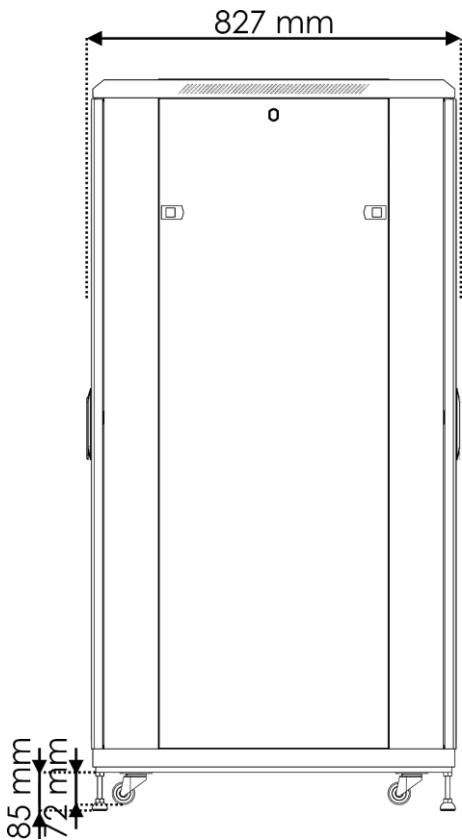

Fig. 13

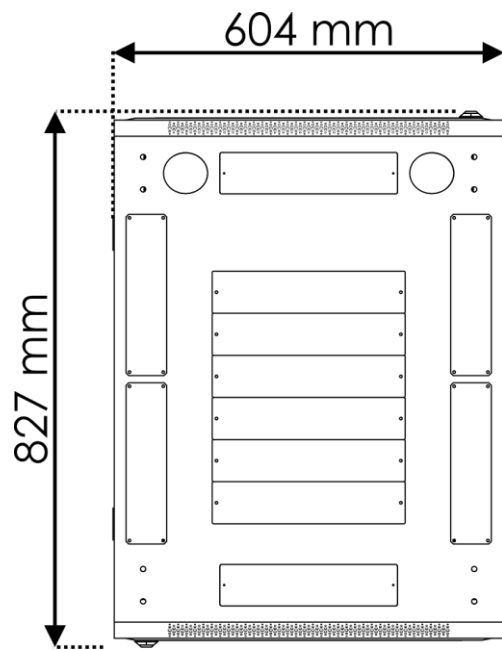

Fig. 14

3.6. Dimensions D7673

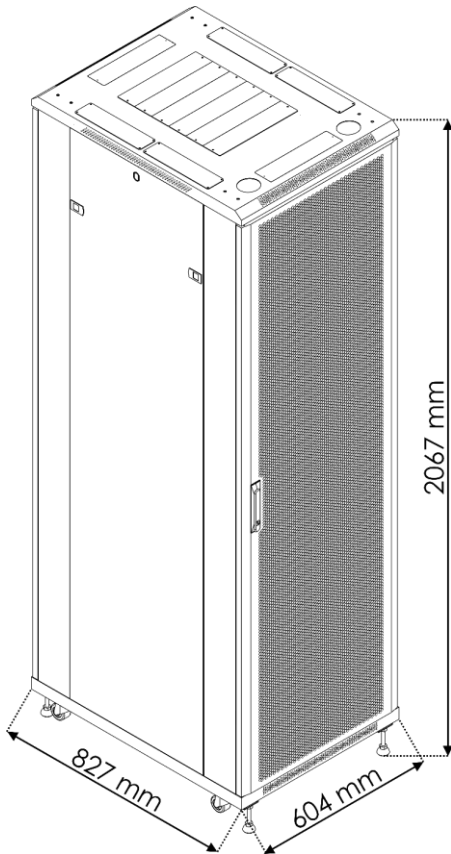

Fig. 15

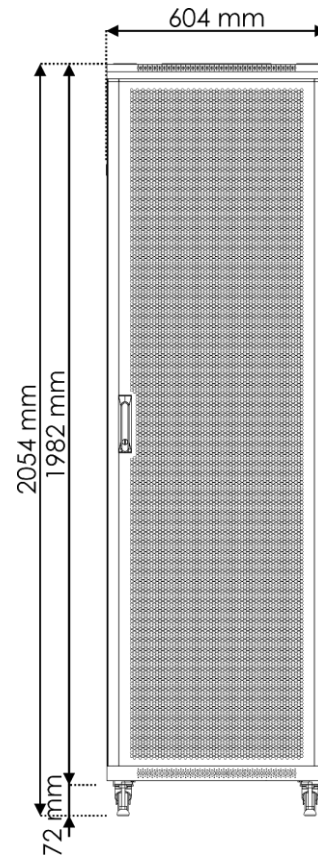

Fig. 16

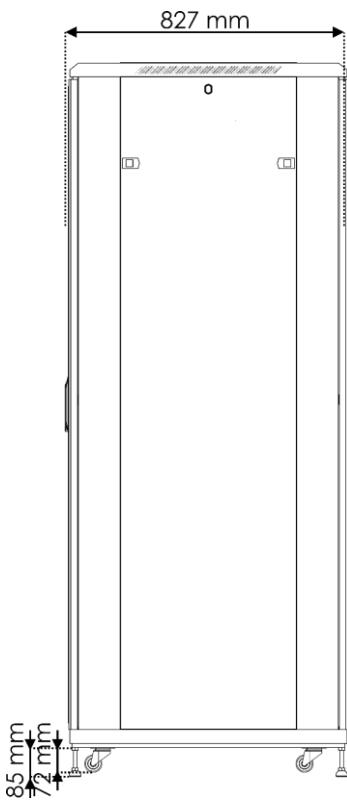

Fig. 17

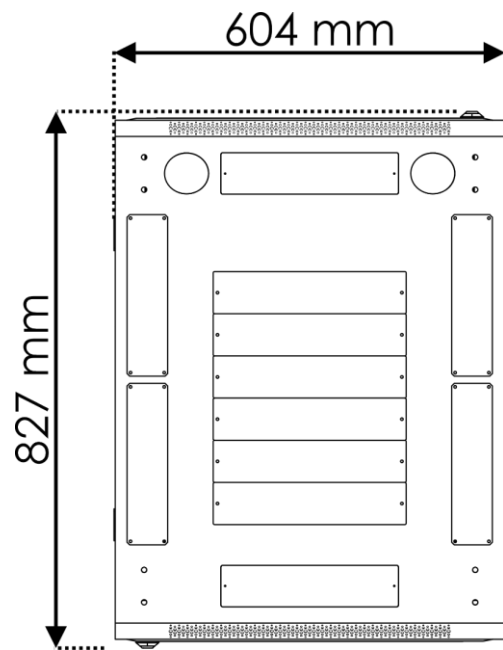

Fig. 18

4. Installation

4.1. Safety Instructions for Installation

**WARNING**

Incorrect installation can cause serious injuries and damage of property.

Installation must be carried out only by instructed or skilled persons.

4.2. Installation Site Requirements

**Attention**

Make sure that there is enough space for ventilation around the cabinet.

- The cabinet must be installed only indoors.
- The cabinet must be placed on a flat leveled surface.
- Keep the cabinet away from moisture, temperature extremes, flammable liquids and gasses, conductive contaminants, dust and direct sunlight.

4.3. Tools for Assembling

To assemble this cabinet, you need:

- Phillips screwdriver (PH1)
- Hex key (5 mm)
- Socket wrench (13)
- Water Level
- Torx T20

4.4. Assembling the Cabinet



Attention
Heavy object

This product is heavy. Minimum two persons are necessary to assemble or to move the cabinet.

To assemble this cabinet follow the steps below:

- 01) Unpack all packages and carefully lay the parts out on the floor.
- 02) Put the 2 **frames (B)** on the **bottom plate (A)**, as shown in Fig. 19.
- 03) Use a socket wrench and a **hex key (R)** to attach the 2 **frames (B)** to the **bottom plate (A)** with 8 **nuts (K)** and 8 **screws (M)**, as shown in Fig. 20.

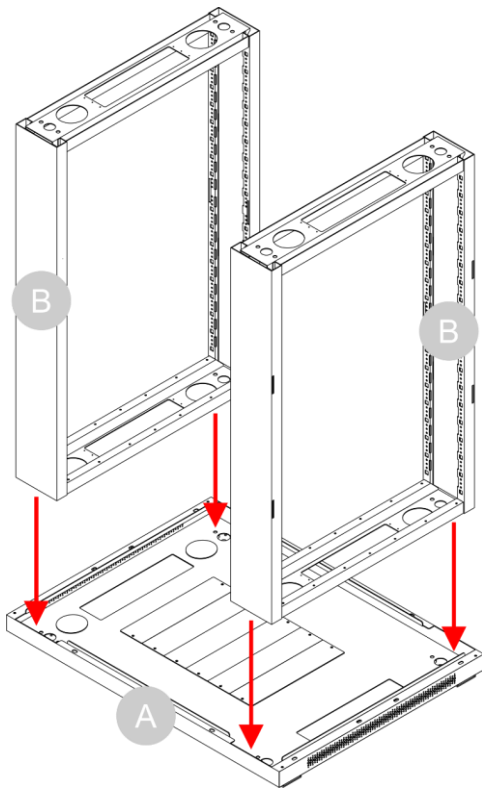

Fig. 19

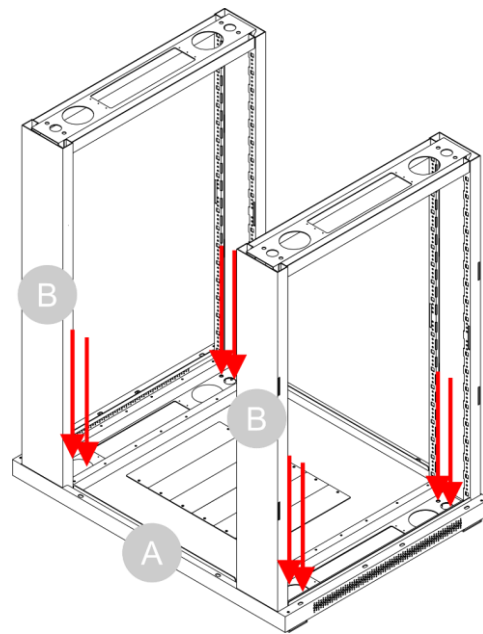

Fig. 20

- 04) Carefully put the cabinet on its side, to make the execution of the following steps easier.
 05) Use a **hex key (R)** to attach the 4 **wheels (J)** to the bottom of the **bottom plate (A)** with 4 x 4 **screws (N)**, as shown in Fig. 21.

Note:

After the wheel installation do not put the cabinet on its wheels, as shown in Fig 22.

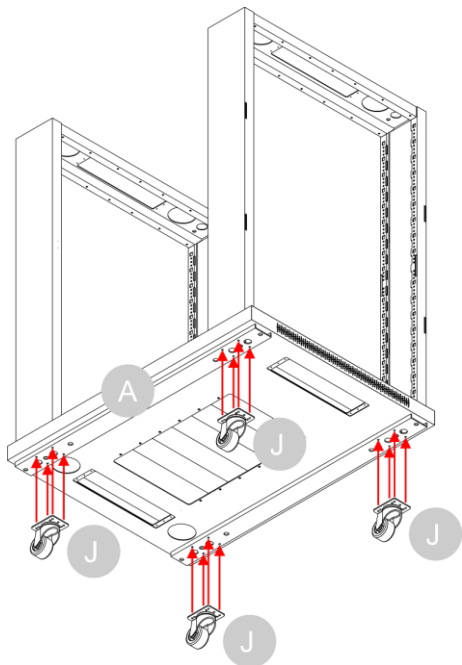

Fig. 21

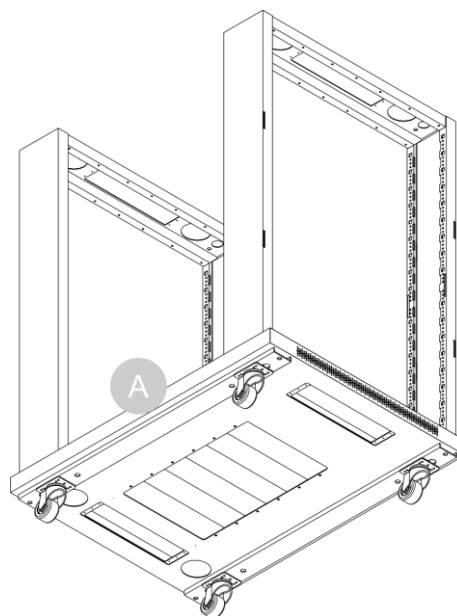

Fig. 22

- 06) Attach the **adjustable feet (I)** to the bottom of the **bottom plate (A)**, by turning them clockwise, as shown in Fig. 23.
 07) Tighten the top nut of the **adjustable feet (I)** with a wrench, as shown in Fig. 24.

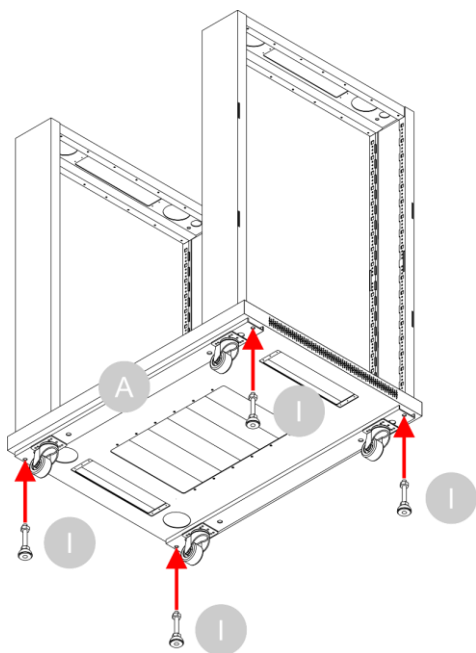

Fig. 23

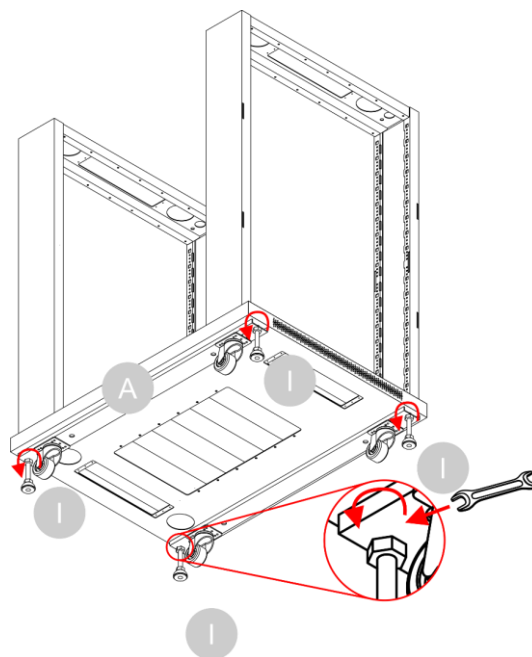

Fig. 24

- 08) Make sure that the **adjustable feet (I)** are extended more than the **wheels (J)**. If necessary, use a wrench to turn the bottom nut of the **adjustable feet (I)** counterclockwise, as shown in Fig. 25. This will prevent the cabinet from rolling on the wheels when you put it in upright position.
- 09) Put the cabinet in upright position.
- 10) Make sure that the cabinet is completely leveled in all directions, as shown in Fig. 26. Adjust the **adjustable feet (I)** if necessary. See step 08.

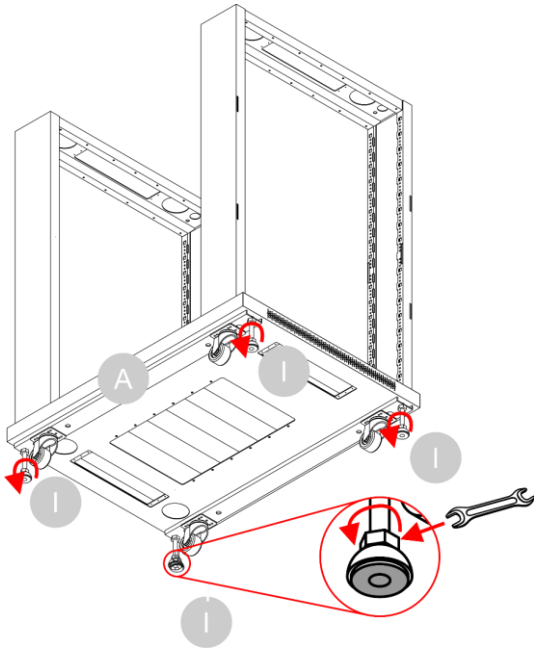

Fig. 25

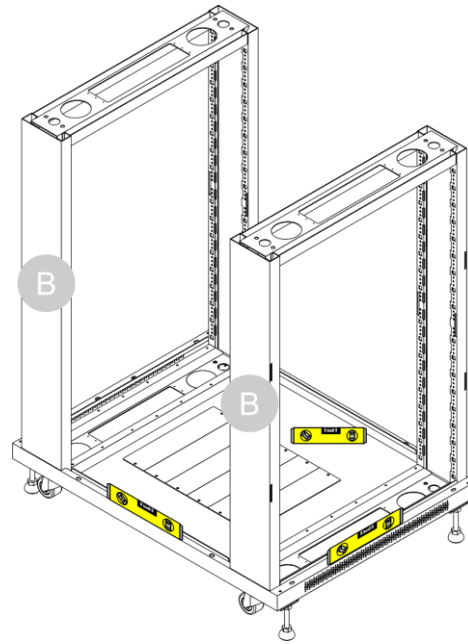

Fig. 26

- 11) Put the **top plate (C)** on top of the 2 **frames (B)**, as shown in Fig. 27.
- 12) Attach the 4 corners of the **top plate (C)** to the 2 **frames (B)** with 4 x 2 **screws (M)**, as shown in Fig. 28.

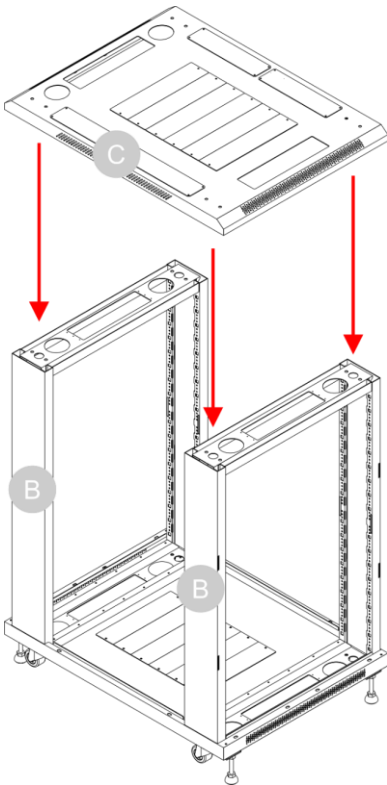

Fig. 27

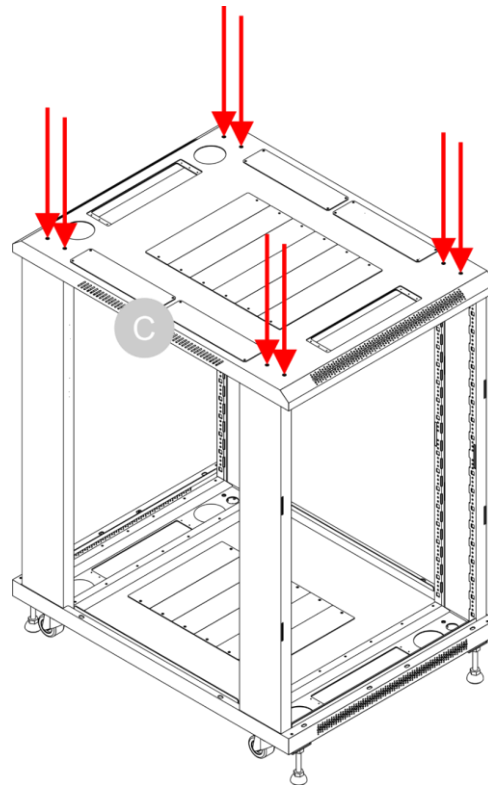

Fig. 28

- 13) Slide the 4 **horizontal brackets (G)** into the holes of the 2 **frames (B)**, as shown in Fig. 29. Make sure that the **horizontal brackets (G)** are installed horizontally and are not inclined.
- 14) Attach the **horizontal brackets (G)** to the 2 **frames (B)** with 4 x 2 **screws (N)** on the 4 top corners of the cabinet and 4 x 2 **screws (N)** on the bottom corners of the cabinet, as shown in Fig. 30.

Note:

You can add 2 more **horizontal brackets (G)**, if you want to add more equipment to the cabinet.

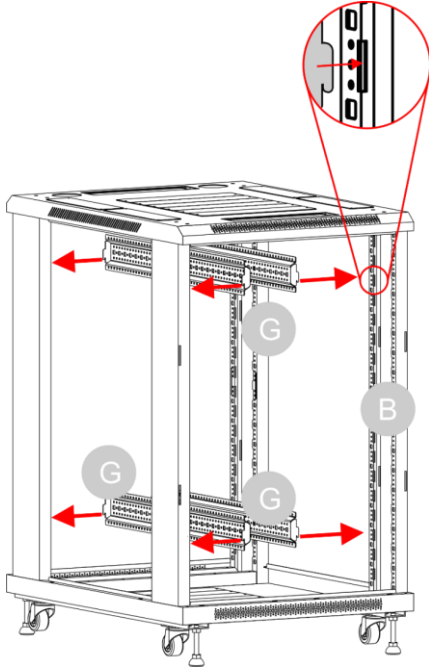

Fig. 29

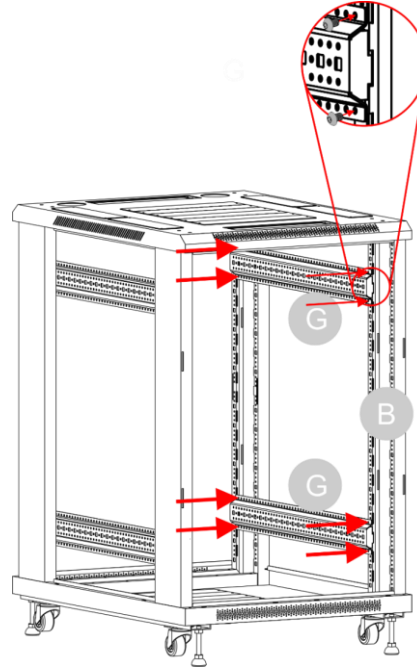

Fig. 30

- 15) Put the 4 **vertical brackets (F)** in front of the **horizontal brackets (G)**. Make sure that the holes of the **vertical brackets (F)** align with the holes of the **horizontal brackets (G)**, as shown in Fig. 31.
- 16) Attach the **vertical brackets (F)** to the **horizontal brackets (G)**. Use 2 **screws (N)** per corner on the 4 top corners of the cabinet and 2 **screws (N)** per corner on the 4 bottom corners of the cabinet, as shown in Fig. 32.

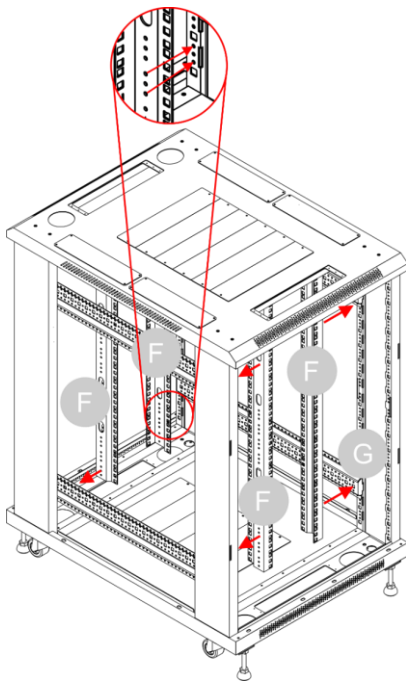

Fig. 31

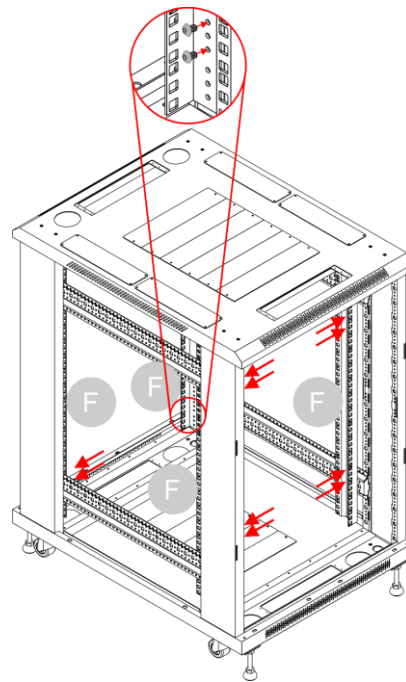

Fig. 32

- 17) Put the 2 **metal plates (H)** on top of the holes of the **top plate (C)**, as shown in Fig. 33.
- 18) Attach the 2 **metal plates (H)** to the **frames (B)** with 2 **screws (N)** per plate, as shown in Fig. 34.

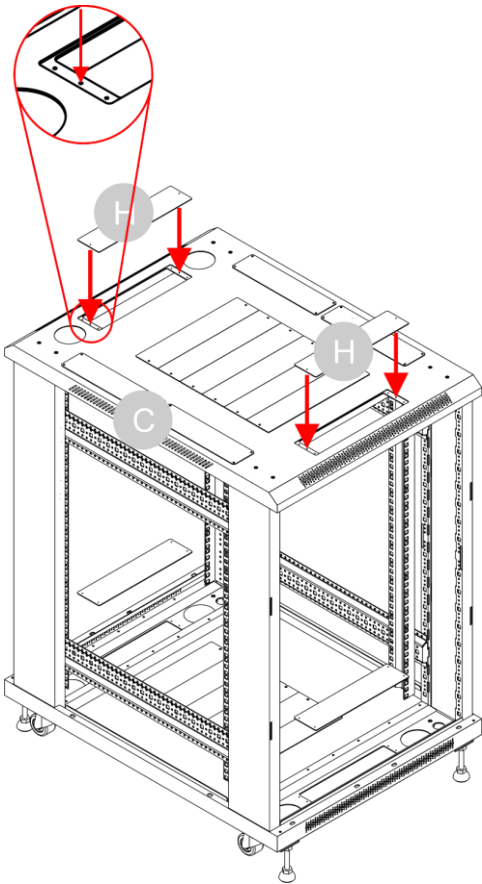

Fig. 33

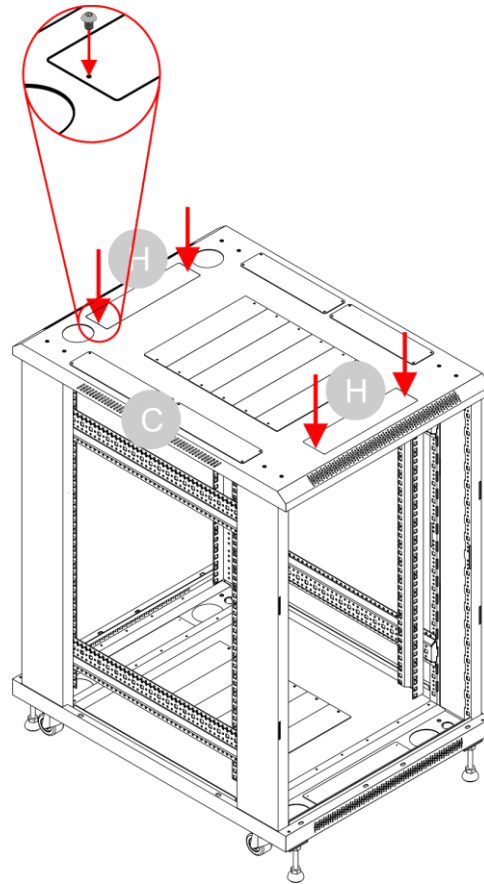

Fig. 34

- 19) Carefully put the **side panel (D)** on the **bottom plate (A)**, so that the 2 pins on the bottom of the **side panel (D)** fit into the holes of the **bottom plate (A)**, as shown in Fig. 35.
- 20) Carefully tilt the **side panel (D)** until it is a few centimeters from the **top plate (C)**, as shown in Fig. 36.

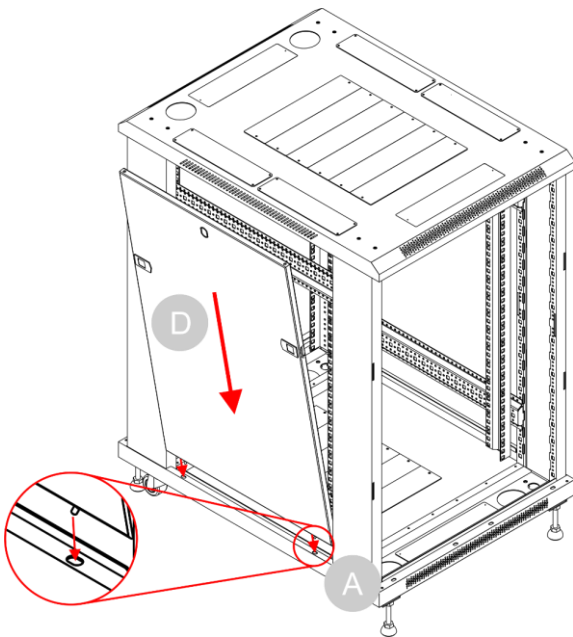

Fig. 35

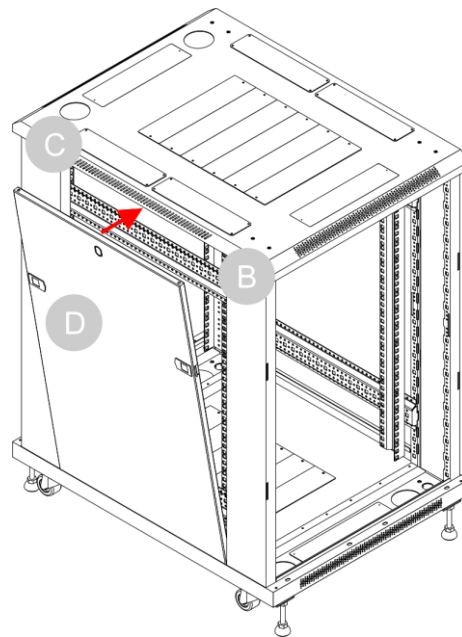

Fig. 36

- 21) Slide the 2 plastic locks of the **side panel (D)** inwards and at the same time carefully close the **side panel (D)**, so that it locks in position, as shown in Fig. 37.
- 22) Repeat steps 19–21 to install the other **side panel (D)**, as shown in Fig. 38.

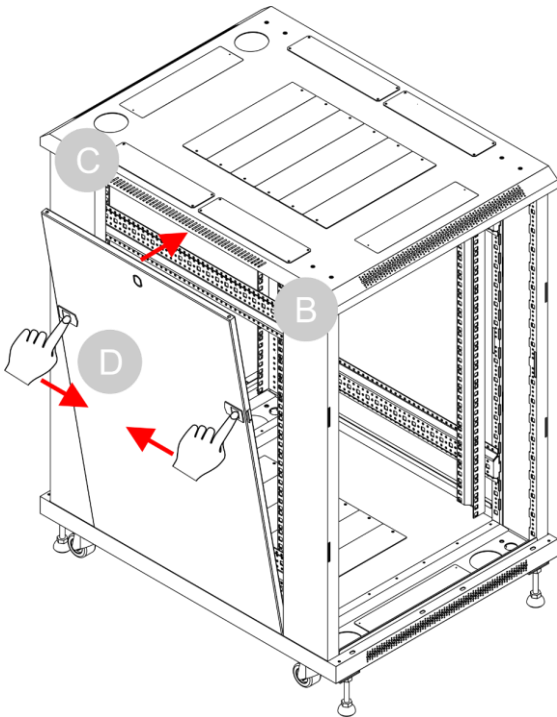

Fig. 37

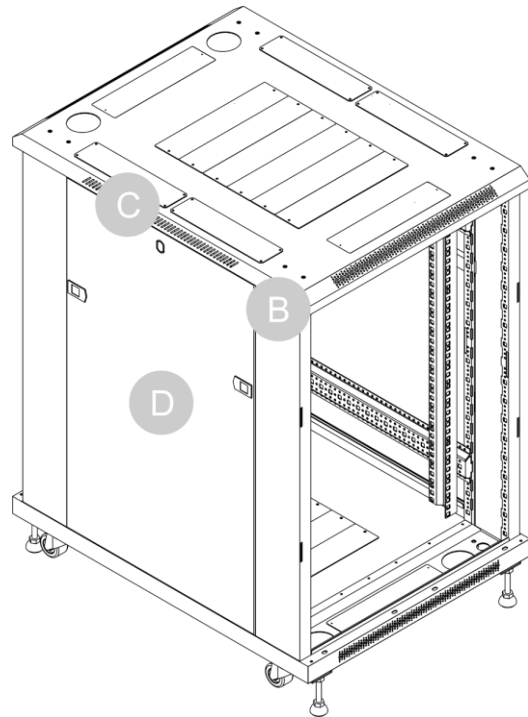

Fig. 38

- 23) Put the **ring (P)** on top of the hole on the **bottom plate (A)**, as shown in Fig. 39.
- 24) Put the **mesh door (E)** in front of the **frame (B)**, so that the pin on the bottom of the **mesh door (E)** fits into the ring and the hole on the **bottom plate (A)**, as shown in Fig. 40.

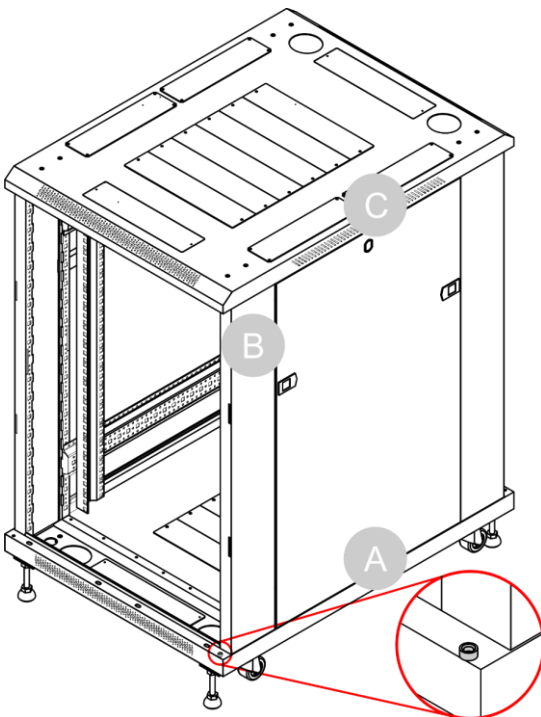

Fig. 39

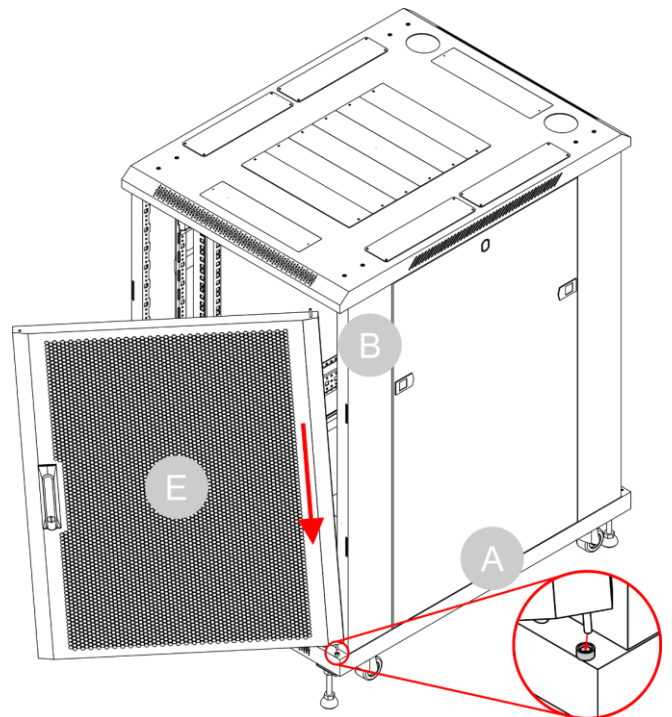

Fig. 40

- 25) Carefully pull down the spring-loaded lever so that lever is aligned with the hole on the bottom of the **top plate (C)** and slowly release it, as shown in Fig. 41. Make sure that the **mesh door (E)** is firmly locked in the hole on the bottom of the **top plate (C)** and the hole on the top of the **bottom plate (A)**.
- 26) Repeat step 25 for the other **mesh door (E)**, as shown in Fig. 42.
- 27) Use 2 sets of **keys (Q)** to lock and unlock the doors. The cabinet is now ready for use.

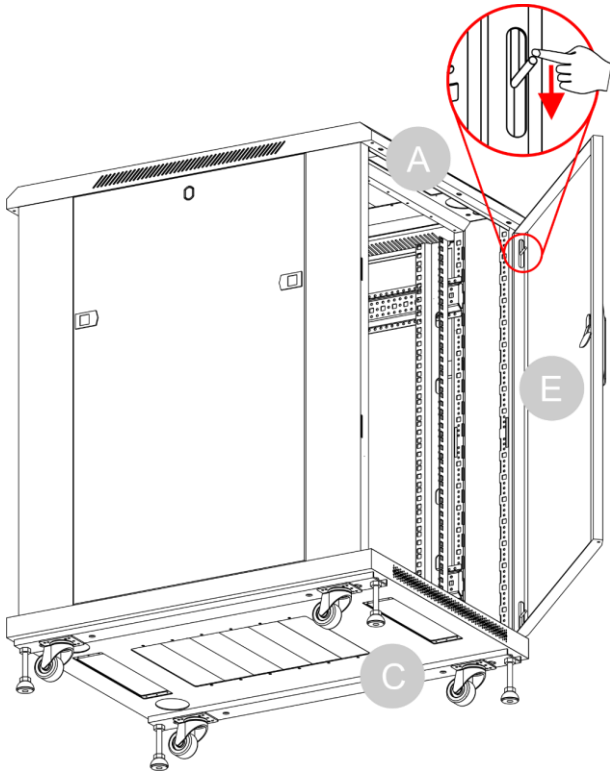

Fig. 41

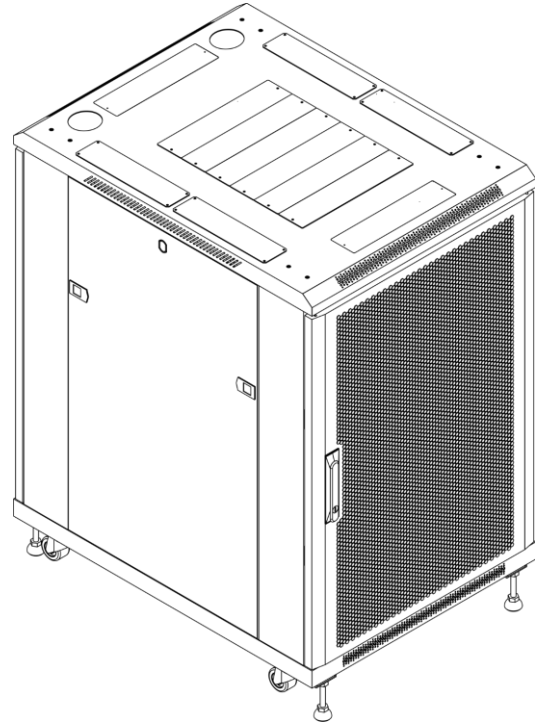

Fig. 42

- 28) Make sure that the cabinet is completely leveled before you install equipment. See step 10 on page 19 to level the cabinet.

4.5. Equipment Installation



WARNING
Stability hazard

This product may fall or tip over, causing serious personal injury and material damage.

- Make sure that the cabinet is fully assembled and secured before you install equipment in the cabinet.
- Do not exceed the maximum load capacity of the cabinet. Make sure that the cabinet can support the total weight of all equipment installed.
- When you install equipment in the cabinet, start with the bottom of the cabinet. Put heavier equipment at the bottom of the cabinet.
- Do not put any object on the cabinet.

You can install standard 19-inch equipment into the server rack cabinet. The inside dimensions of the server rack cabinet are as follows:

- D7670 RCA-FSM-18: 18 U
- D7671 RCA-FSM-22: 22 U
- D7672 RCA-FSM-32: 32 U
- D7673 RCA-FSM-42: 42 U

1 rack unit is 44,45 mm high.

To mount equipment, follow the steps below:

- 01) Put 4 **cage nuts (L)** in front of the holes on the **vertical brackets (F)** at the place where you want to mount the equipment, as shown in Fig. 43.
- 02) Insert one side of the **cage nut (L)** into the **vertical bracket (F)**, as shown in Fig. 44.

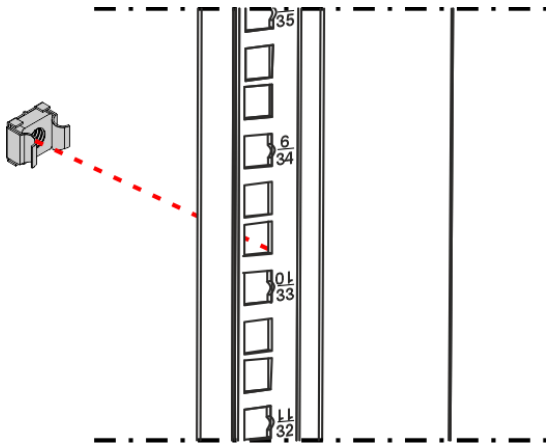

Fig. 43

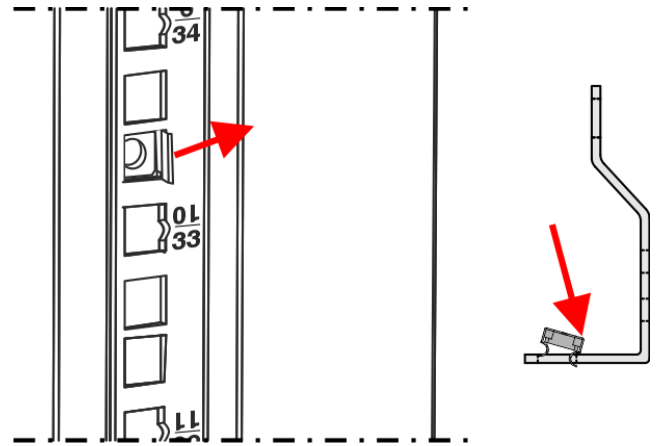

Fig. 44

- 03) Press the other side of the **cage nut (L)** and push it through the hole, as shown in Fig. 45.
- 04) Repeat steps 2–3 to install the other 3 **cage nuts (L)**.
- 05) Put the equipment in front of the cabinet at the place where the 4 **cage nuts (L)** are installed. Make sure that the mounting holes on the equipment are aligned with the **cage nuts (L)**, as shown in Fig. 46.
- 06) Use a screwdriver to mount the equipment to the **vertical brackets (G)** with 4 **screws (O)**.
- 07) Tighten the 4 **screws (O)** to make sure that the equipment cannot move.

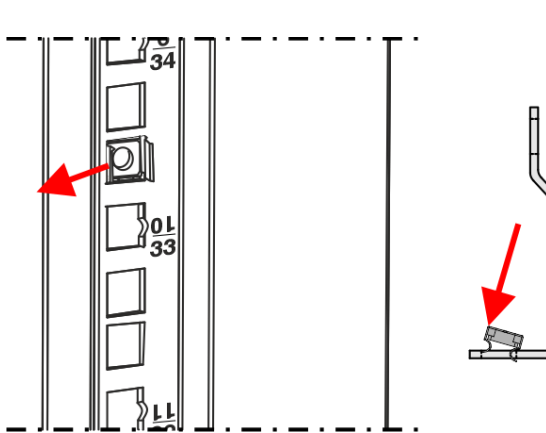

Fig. 45

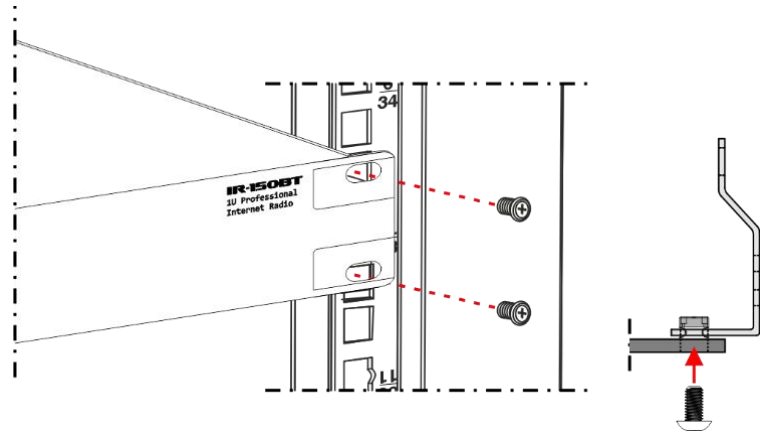

Fig. 46

5. Maintenance

5.1. Preventive Maintenance

**Attention**

Before use, examine the cabinet visually for any defects.

Make sure that:

- All screws used for installing the cabinet are tightly fastened and are not corroded.
- There are no deformations on materials.

5.1.1. Basic Cleaning Instructions

The ventilation openings must be cleaned periodically in order to optimize airflow and keep the installed equipment dust-free. The cleaning schedule depends on the conditions at the site where the cabinet is installed.

**Attention**

Do not use alcohol or solvents.

To clean the product, follow the steps below:

- 01) Clean the product with a soft, lint-free cloth.
- 02) Remove dust from the ventilation openings with an air compressor, vacuum cleaner or a soft brush.

5.2. Corrective Maintenance

The product does not contain user-serviceable parts. Do not modify the product.

Refer repairs and servicing to instructed or skilled persons. Contact your Highlite International dealer for more information.

6. Deinstallation, Transportation and Storage

6.1. Instructions for Deinstallation



Attention
Heavy object

This product is heavy. Minimum two persons are necessary to disassemble or to move the cabinet.

- Deinstallation must be carried out only by instructed or skilled persons.
- When you remove equipment from the cabinet, start with the top of the cabinet.
- Do not put any equipment on the cabinet.

To deinstall the product, follow the steps below:

- 01) Remove the installed equipment from the cabinet. Make sure that you first remove equipment installed at the top of the cabinet.
- 02) Clean the cabinet. See **5.1.1. Basic Cleaning Instructions** on page 26.
- 03) Disassemble the cabinet. Follow steps 01–28 from **4.4. Assembling the Cabinet** on pages 17–23 in reverse order.

6.2. Instructions for Transportation

- Use the original packaging to transport the product, if possible.
- Always observe the handling instructions printed on the outer carton box, for example: "Handle with care", "This side up", "Fragile".

6.3. Storage

- Inspect the product for defects before storing. See **5.1. Preventive Maintenance** on page 26 for more information.
- Clean the product before storing. Follow the cleaning instructions in chapter **5.1.1. Basic Cleaning Instructions** on page 26.
- Store the product in the original packaging, if possible.

7. Disposal

After the product is removed from service all metal parts can be disposed of as scrap. The plastic and rubber parts of this product shall not be treated as household waste. Dispose of these plastic and rubber parts by handing it to the respective collection point for recycling. This is to avoid environmental damage or personal injury due to uncontrolled waste disposal. For more detailed information about recycling of this product contact the local authorities or the authorized dealer



©2022 Showgear