

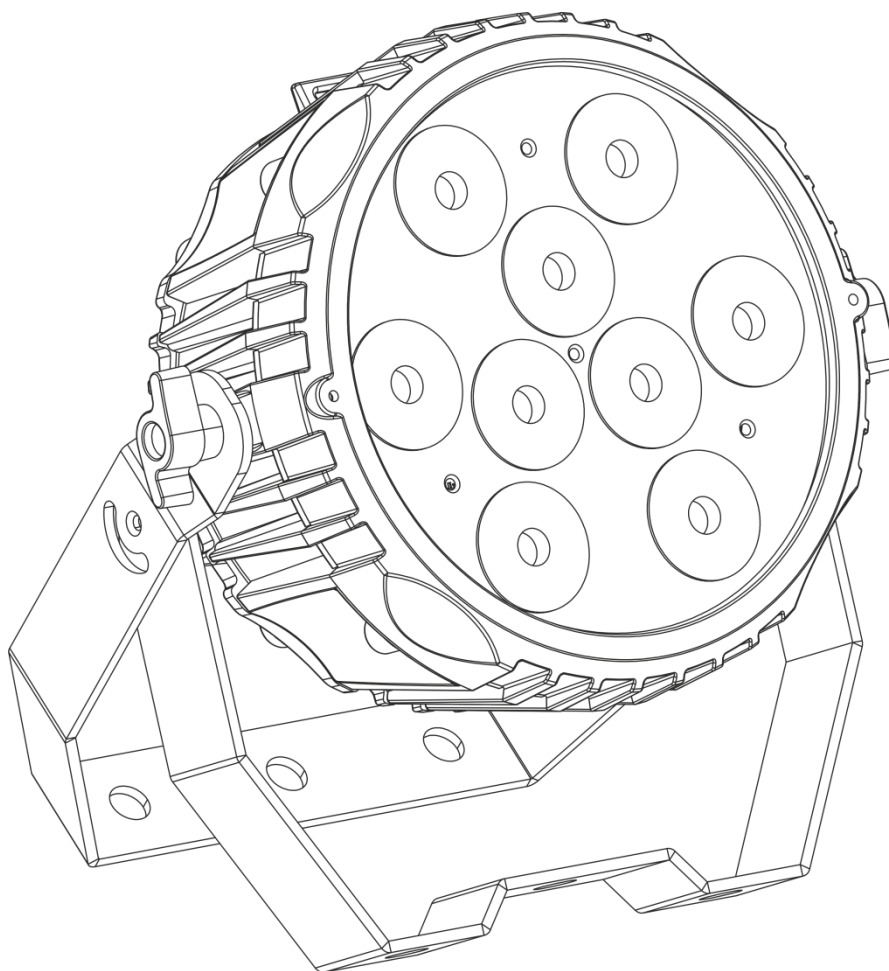

MANUAL



ENGLISH

Power Spot 9 Q6 Tour

V2

Ordercode: 42576

Table of contents

Warning2
 Unpacking Instructions.....2
 LED Expected Lifespan2
 Safety Instructions2
 Operating Determinations4
 Rigging4
 Connection with the mains.....5
 Return Procedure.....6
 Claims.....6

Description of the device.....7
 Frontside.....8
 Backside9

Installation.....10

Setup and Operation10
 Control Modes.....10
 One Power Spot (Manual Mode, Auto Mode and Built-in programs)10
 One Power Spot (Sound-controlled)10
 Multiple Power Spots (Master/Slave control)10
 Multiple Power Spots (DMX Control)11
 Fixture Linking12
 Data Cabling12
 Control Panel13
 Control Mode13
 DMX Addressing13
 Menu Overview14
 Main Menu Options15
 1. DMX Addressing.....15
 2. Sound-controlled.....15
 3. Manual Mode (Static Color Mode)15
 4. Settings.....16
 4.1. LCD Backlight16
 4.2. Factory Reset.....16
 5. Info.....16
 6. Auto Mode.....16
 8. Slave Mode17
 DMX Channels18
 6 channels18
 8 channels18
 10 channels.....19

Maintenance20

Troubleshooting20
 No Light21
 No Response to DMX.....21

Product Specifications22

Dimensions.....23

Notes24

Warning



**For your own safety, please read this user manual carefully
before your initial start-up!**



Unpacking Instructions

Immediately upon receiving this product, carefully unpack the carton and check the contents to ensure that all parts are present, and have been received in good condition. Notify the dealer immediately and retain packing material for inspection if any parts appear damaged from shipping or the carton itself shows signs of mishandling. Save the carton and all packing materials. In the event that a fixture must be returned to the factory, it is important that the fixture be returned in the original factory box and packing.

Your shipment includes:

- Showtec Power Spot 9 Q6 Tour
- Schuko to pro power cable (1,5 m)
- User manual

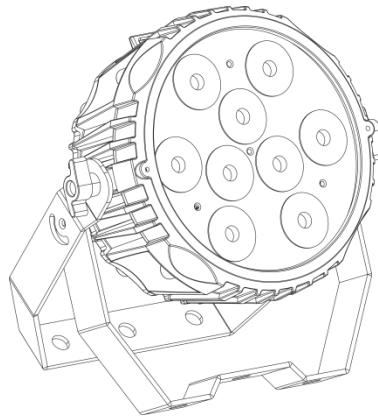

LED Expected Lifespan

LEDs gradually decline in brightness over time. HEAT is the dominant factor that leads to the acceleration of this decline. Packaged in clusters, LEDs exhibit higher operating temperatures than in ideal or singular optimum conditions. For this reason, when all color LEDs are used at their fullest intensity, life of the LEDs is significantly reduced. If improving the lifespan is of higher priority, place care in providing for lower operational temperatures. This may include climatic-environmental and the reduction of overall projection intensity.



CAUTION!

**Keep this device away from rain and moisture!
Unplug mains lead before opening the housing!**



Safety Instructions

Every person involved with the installation, operation and maintenance of this device has to:

- be qualified
- follow the instructions of this manual



**CAUTION! Be careful with your operations.
With a dangerous voltage you can suffer
a dangerous electric shock when touching the wires!**



Before the initial start-up, please make sure that there is no damage caused by transportation. Should there be any, consult your dealer and do not use the device.

To maintain perfect condition and to ensure a safe operation, it is absolutely necessary for the user to follow the safety instructions and warning notes contained in this manual.

Please consider that damages caused by manual modifications to the device are not subject to warranty.

This device contains no user-serviceable parts. Refer servicing to qualified technicians only.

IMPORTANT:

The manufacturer will not accept liability for any resulting damages caused by the non-observance of this manual or any unauthorized modification to the device.

- Never let the power cord come into contact with other cables! Handle the power cord and all connections with the mains with particular caution!
- Never remove warning or informative labels from the unit.
- Never use anything to cover the ground contact.
- Never lift the fixture holding it by the projector-head, as the mechanics may be damaged. Always hold the fixture by the transport handles.
- Never place any material over the lens.
- Never look directly into the light source.
- Never leave any cables lying around.
- Do not insert objects into air vents.
- Do not connect this device to a dimmer pack.
- Do not switch the device on and off in short intervals, as this will reduce the device's life.
- Do not touch the device's housing bare-handed during its operation (housing becomes very hot). Allow the fixture to cool for at least 5 minutes before handling.
- Do not shake the device. Avoid brute force when installing or operating the device.
- Only use the device indoors, avoid contact with water or other liquids.
- Only operate the fixture after having checked if the housing is firmly closed and all screws are tightly fastened.
- Only operate the device after having familiarized with its functions.
- Avoid flames and do not put close to flammable liquids or gases.
- Always keep the case closed while operating.
- Always allow a free air space of at least 50 cm around the unit for ventilation.
- Always disconnect power from the mains, when device is not used or before cleaning! Only handle the power cord holding it by the plug. Never pull out the plug by tugging the power cord.
- Make sure that the device is not exposed to extreme heat, moisture or dust.
- Make sure that the available voltage is not higher than stated on the rear panel.
- Make sure that the power cord is never crimped or damaged. Check the device and the power cord from time to time.
- If the lens is obviously damaged, it has to be replaced.
- If device was dropped or struck, disconnect mains power supply immediately. Have a qualified engineer inspect for safety before operating.
- If the device has been exposed to drastic temperature fluctuation (e.g. after transportation), do not switch it on immediately. The arising condensation water might damage your device. Leave the device switched off until it has reached room temperature.
- If your Showtec device fails to work properly, discontinue the use immediately. Pack the unit securely (preferably in the original packing material), and return it to your Showtec dealer for service.
- For adult use only. The fixture must be installed beyond the reach of children. Never leave the unit running unattended.
- Never attempt to bypass the thermostatic switch or fuses.
- For replacement use fuses of same type and rating only.
- The user is responsible for correct positioning and operating of the Power Spot. The manufacturer will not accept liability for damages caused by the misuse or incorrect installation of this device.
- This device falls under protection class I. Therefore it is essential to connect the yellow/green conductor to earth.

- During the initial start-up some smoke or smell may arise. This is a normal process and does not necessarily mean that the device is defective.
- Repairs, servicing and electric connection must be carried out by a qualified technician.
- WARRANTY: Till one year after date of purchase.



Operating Determinations

- This device is not designed for permanent operation. Consistent operation breaks will ensure that the device will serve you for a long time without defects.
- The minimum distance between light output and the illuminated surface must be bigger than 0,2 meter.
- The maximum ambient temperature $t_a = 40\text{ °C}$ must never be exceeded.
- The relative humidity must not exceed 50 % with an ambient temperature of 40 °C.
- If this device is operated in any other way than the one described in this manual, the product may suffer damages and the warranty becomes void.
- Any other operation may lead to dangers like short-circuit, burns, electric shock, crash, etc.

You endanger your own safety and the safety of others!

Rigging

Please follow the European and national guidelines concerning rigging, trussing and all other safety issues.

Do not attempt the installation yourself !

Always let the installation be carried out by an authorized dealer !

Procedure:

- If the device is lowered from the ceiling or high joists, professional trussing systems have to be used.
- Use a clamp to mount the device, with the mounting bracket, to the trussing system.
- The device must never be fixed swinging freely in the room.
- The installation must always be secured with a safety attachment, e.g. an appropriate safety net or safety cable.
- When rigging, derigging or servicing the projector, always make sure, that the area below the installation site is secured and that there are not any unauthorized people around.

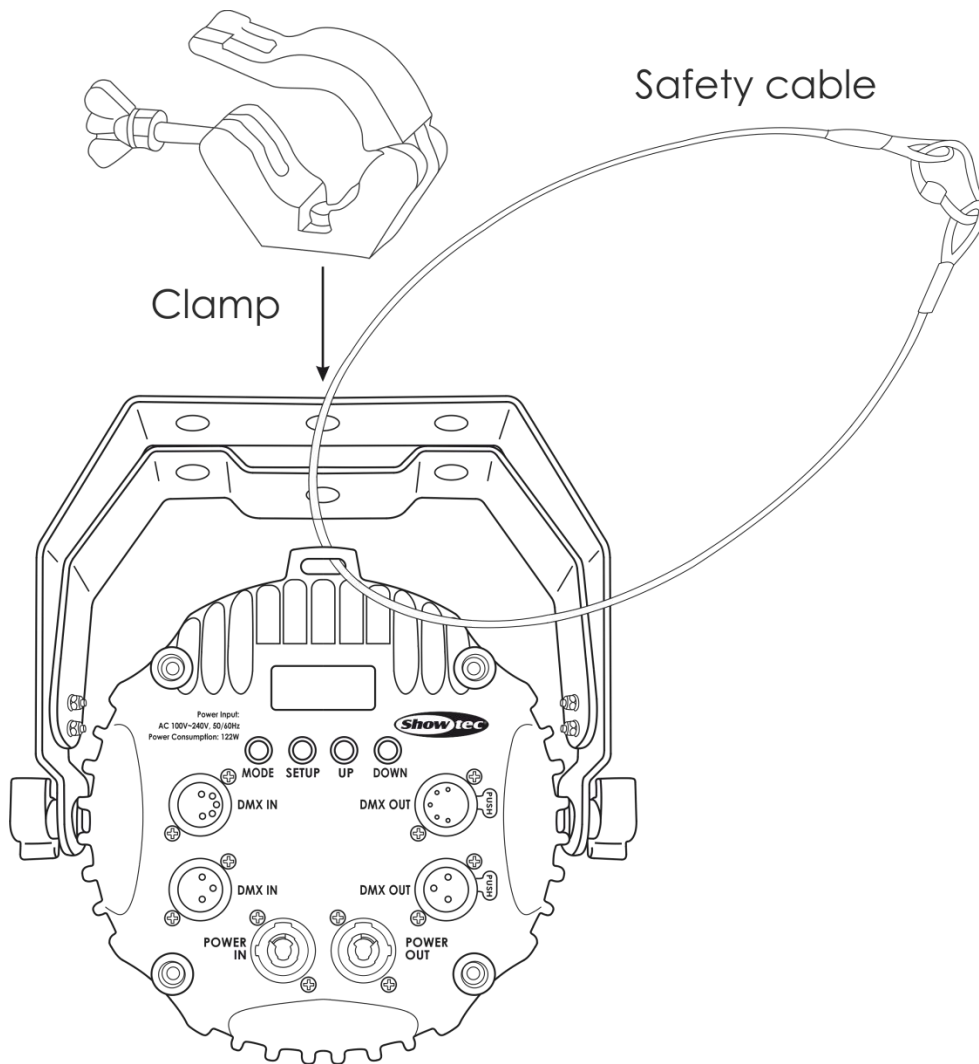

The Power Spot can be placed on a flat stage floor or mounted to any kind of truss with a clamp.

Improper installation can cause serious injuries and/or damage of property!

Connection with the mains

Connect the device to the mains with the power-plug.
Always check if the right color cable is connected to the right place.

International	EU Cable	UK Cable	US Cable	Pin
L	BROWN	RED	YELLOW/COPPER	PHASE
N	BLUE	BLACK	SILVER	NEUTRAL
⊕	YELLOW/GREEN	GREEN	GREEN	PROTECTIVE GROUND

Make sure that the device is always properly connected to the earth!

Improper installation can cause serious injuries and/or damage of property!



Return Procedure

Returned merchandise must be sent prepaid and in the original packing, call tags will not be issued. Package must be clearly labeled with a Return Authorization Number (RMA number). Products returned without an RMA number will be refused. Highlite will not accept the returned goods or any responsibility. Call Highlite 0031-455667723 or mail offersales@highlite.com and request an RMA prior to shipping the fixture. Be prepared to provide the model number, serial number and a brief description of the cause for the return. Be sure to properly pack fixture, any shipping damage resulting from inadequate packaging is the customer's responsibility. Highlite reserves the right to use its own discretion to repair or replace product(s). As a suggestion, proper UPS packing or double-boxing is always a safe method to use.

Note: If you are given an RMA number, please include the following information on a piece of paper inside the box:

- 01) Your name
- 02) Your address
- 03) Your phone number
- 04) A brief description of the symptoms

Claims

The client has the obligation to check the delivered goods immediately upon delivery for any shortcomings and/or visible defects, or perform this check after our announcement that the goods are at their disposal. Damage incurred in shipping is the responsibility of the shipper; therefore the damage must be reported to the carrier upon receipt of merchandise.

It is the customer's responsibility to report and submit claims with the shipper in the event that a fixture is damaged due to shipping. Transportation damage has to be reported to us within one day after receipt of the delivery.

Any return shipment has to be made post-paid at all times. Return shipments must be accompanied with a letter defining the reason for return shipment. Non-prepaid return shipments will be refused, unless agreed otherwise in writing.

Complaints against us must be prepared in writing or sent by fax within 10 working days after receipt of the invoice. After this period complaints will not be handled anymore.

Complaints will only then be considered if the client has so far complied with all parts of the agreement, regardless of the agreement from which the obligation is resulting.

Description of the device

Features

The Power Spot 9 Q6 Tour is an ultra-compact light effect with high output and great effects. It is the ideal solution for small clubs and mobile DJs.

- Input voltage: 100–240 V AC, 50/60 Hz
- Power consumption: 64,1 W
- DMX channels: 6, 8 or 10
- LCD display
- Light source: 9 x 6-in-1 12W LED RGBWA-UV
- Control modes: Built-in programs, Auto, DMX, Slave, Sound-controlled, Manual
- Control protocol: DMX-512
- Dimmer: 0–100 %
- Strobe: 0–20 Hz
- Flicker free (Suitable for TV Studio)
- Refreshrate: 7,8 kHz
- Beam angle: 18°
- Convection cooling, 100 % silent / Forced Convection
- Working temperature: From -10 °C to 40 °C
- Power linking: 19 pcs @ 240 V, 8 pcs @ 110 V
- Housing: Die cast aluminum, powder coat finish
- Connections: Blue / White pro power connector IN/OUT
- 3-pin + 5-pin XLR IN/OUT
- Dimensions: 264 x 113 x 294 mm (LxWxH)
- Weight: 2,84 kg

Lux @ 1–5m	1 m	2 m	3 m	4 m	5 m
Red	2348	630	279	166	103
Green	4475	1108	490	273	178
Blue	773	203	90	52	32
White	4625	1235	580	308	202
Amber	1976	520	228	135	78
UV	30	10	7	3	1,5
FULL ON	12050	3230	1213	765	462

Frontside

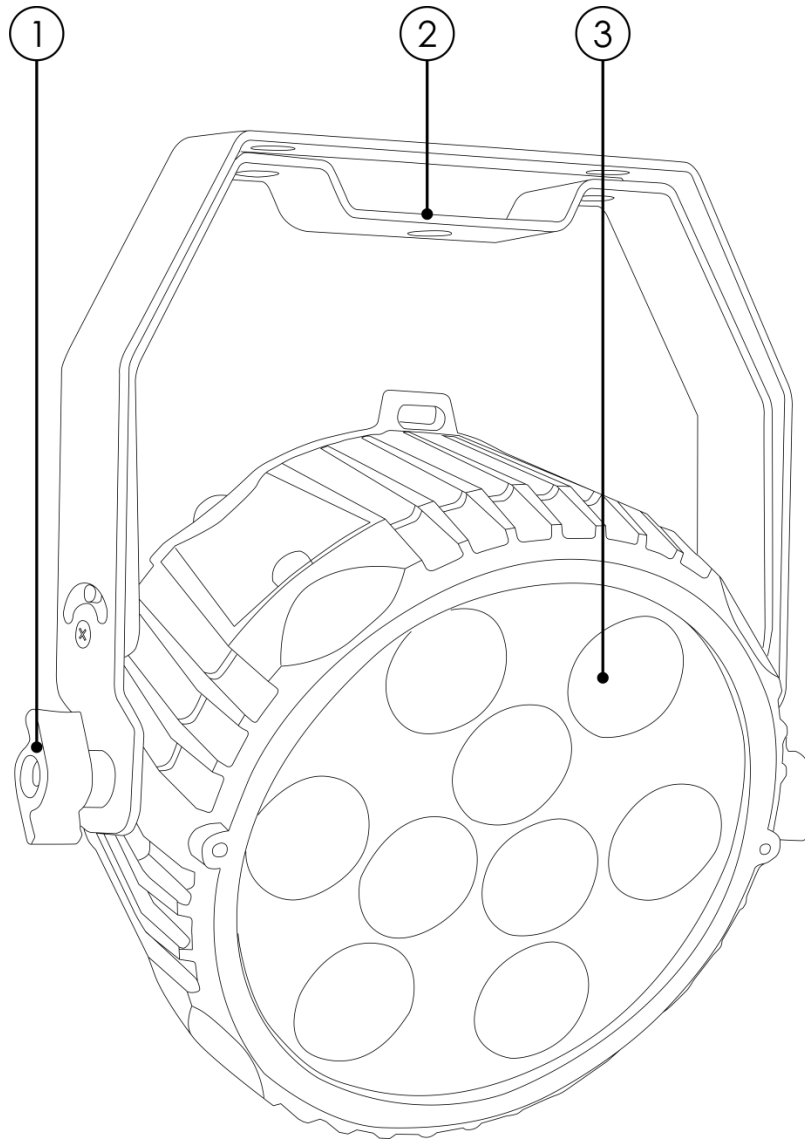

Fig. 01

- 01) Adjustment screw
- 02) Double mounting bracket
- 03) 9 x 6-in-1 12 W LED RGBWA-UV

Backside

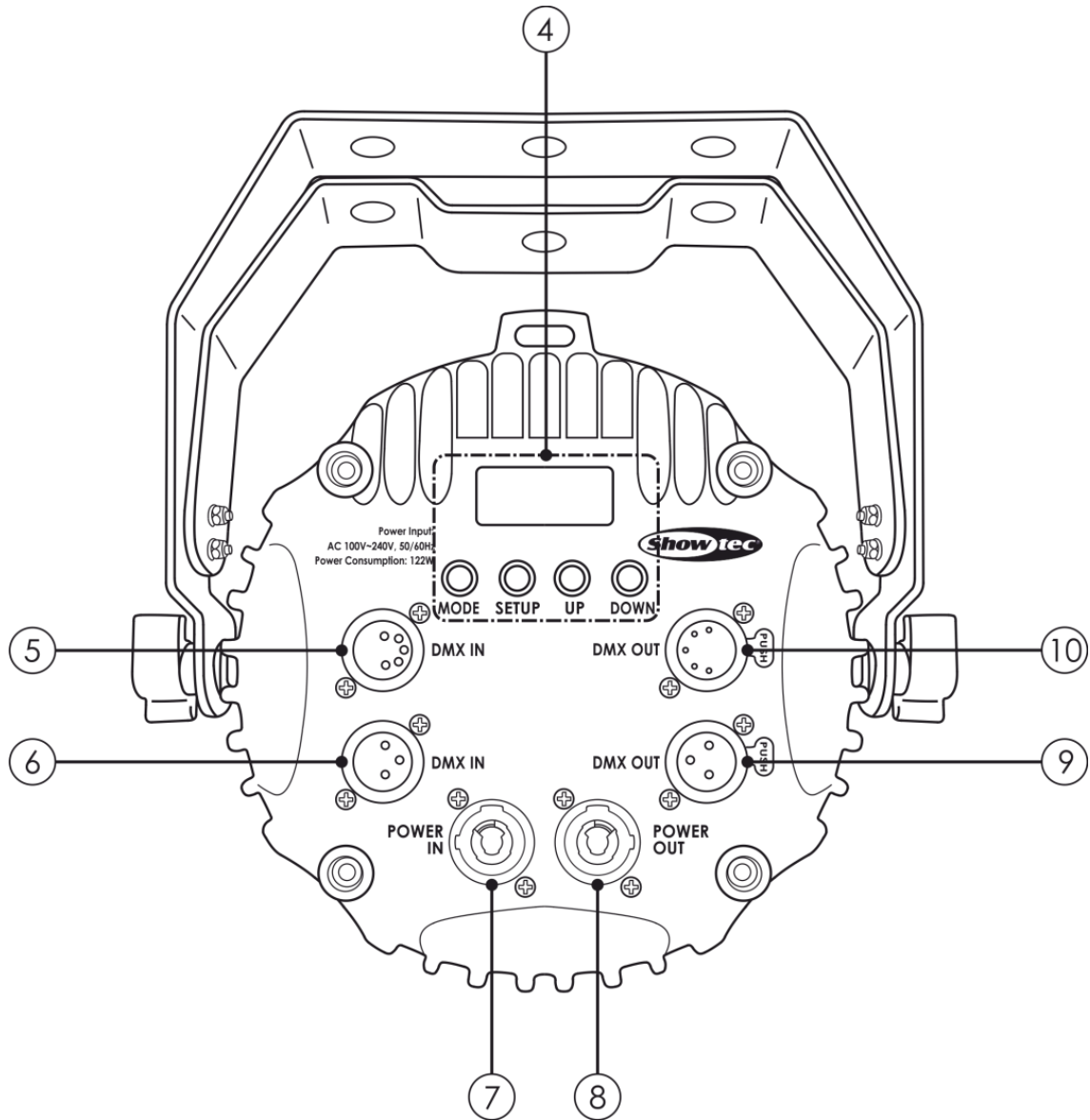

Fig. 02

- 04) LCD display + control buttons
- 05) 5-pin DMX signal connector IN
- 06) 3-pin DMX signal connector IN
- 07) Blue power connector 100-240 V IN
- 08) White power connector 100-240 V OUT
- 09) 3-pin DMX signal connector OUT
- 10) 5-pin DMX signal connector OUT

Installation

Remove all packing materials from the Power Spot 9 Q6 Tour. Check if all foam and plastic padding is removed. Connect all cables.

Do not supply power before the whole system is set up and connected properly.

Always disconnect from electric mains power supply before cleaning or servicing.

Damages caused by non-observance are not subject to warranty.

Setup and Operation

Follow the directions below, as they pertain to your preferred operation mode.

Before plugging the unit in, always make sure that the power supply matches the product specification voltage. Do not attempt to operate a 120 V specification product on 230 V power, or vice versa.

Connect the device to the main power supply. The device can be sound-controlled as it is equipped with a built-in microphone.

Control Modes

There are 6 modes:

- Manual Mode (Static Color)
- Auto Mode
- Built-in programs
- Sound-controlled
- Master/Slave
- DMX-512 (6CH, 8CH, 10CH)

One Power Spot (Manual Mode, Auto Mode and Built-in programs)

- 01) Fasten the effect light to a firm trussing. Leave at least 0,5 meter on all sides for air circulation.
- 02) Plug the end of the electric mains power cord into a proper electric power supply socket.
- 03) When the Power Spot is not connected with a DMX cable, it functions as a stand-alone device.
- 04) Please see page 15–17 for more information about the Built-in programs, Auto Mode and Manual Mode.

One Power Spot (Sound-controlled)

- 01) Fasten the effect light to a firm trussing. Leave at least 0,5 meter on all sides for air circulation.
- 02) Plug the end of the electric mains power cord into a proper electric power supply socket.
- 03) Turn on the music. If the device is set to sound-control, then the Power Spot will react to the beat of the music.
- 04) Please see page 15 for more information about the sound-control options.

Multiple Power Spots (Master/Slave control)

- 01) Fasten the effect light onto firm trussing. Leave at least 0,5 meter on all sides for air circulation.
- 02) Use a 3-pin XLR cable to connect the Power Spot.

The pins:



- 01) Earth
- 02) Signal -
- 03) Signal +

- 03) Link the units as shown in Fig. 03. Connect the first unit's DMX "out" socket with the second unit's "in" socket, using a DMX-signal cable. Repeat this process to link the second, third, and fourth units. You can use the same functions on the master device as described on pages 15–17 (Built-in programs, Auto Mode, Manual Mode or Sound-controlled Mode). This means that you can set your desired operation mode on the master device and all slave devices will react the same as the master device.

Multiple Power Spots (Master/Slave control)

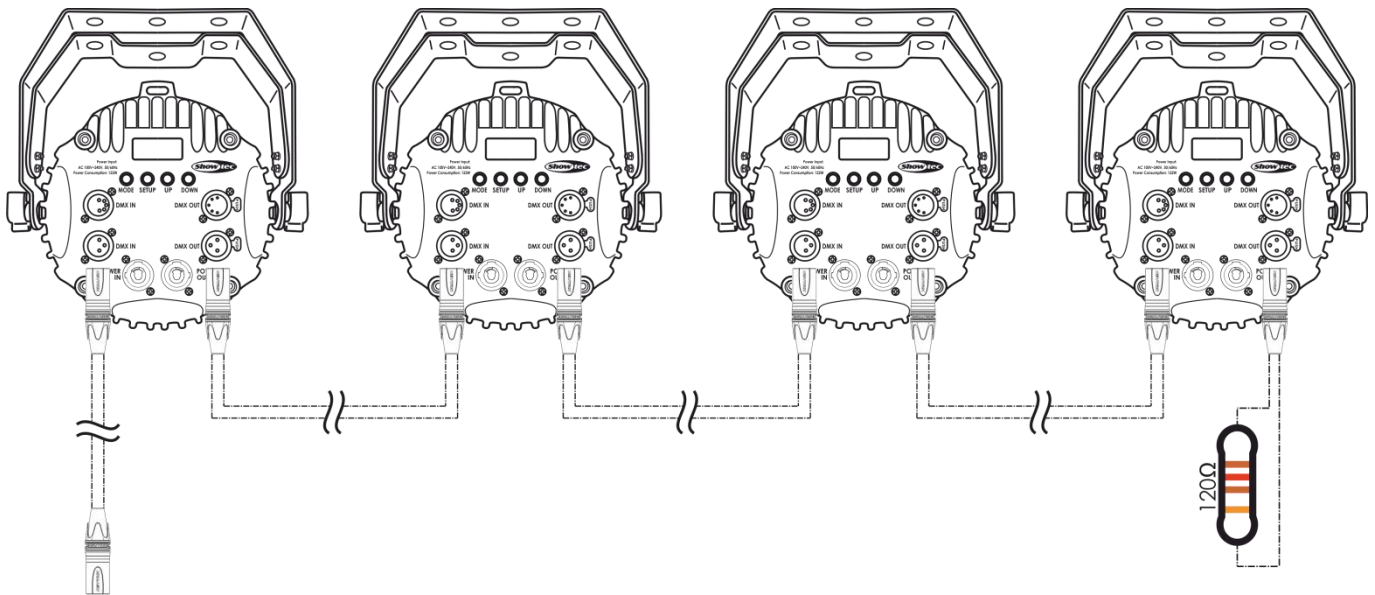
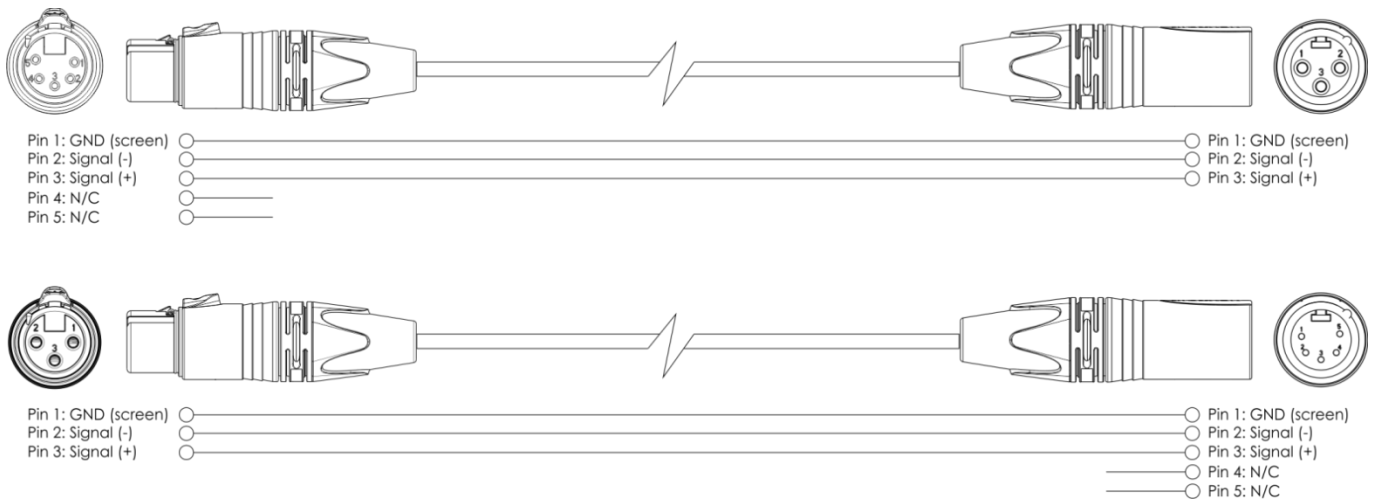

Fig. 03

Multiple Power Spots (DMX Control)

- 01) Fasten the effect light to a firm trussing. Leave at least 0,5 meter on all sides for air circulation.
- 02) Always use a safety cable (ordercode 70140 / 70141).
- 03) Use a 3-pin XLR cable to connect the Power Spots and other devices.



- 04) Link the units as shown in Fig. 04. Connect the first unit's DMX "out" socket with the second unit's "in" socket, using a DMX-signal cable. Repeat this process to link the second, third, and fourth units.
- 05) Supply electric power: Plug electric mains power cords into each unit's pro power socket, then plug the other end of the mains power cord into proper electric power supply sockets, starting with the first unit. Do not supply power before the whole system is set up and connected properly.

Multiple Power Spots DMX Setup

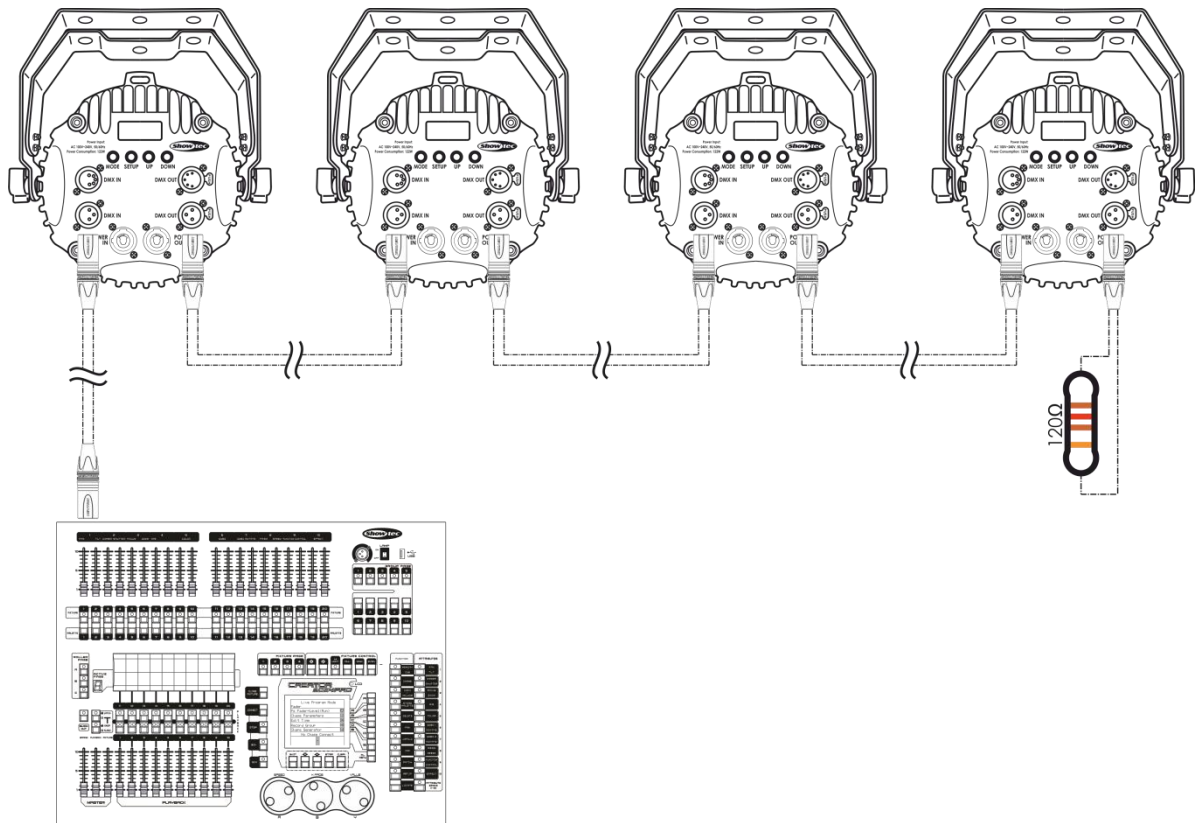

Fig. 04

Note : Link all cables before connecting electric power

Fixture Linking

You will need a serial data link to run light shows of one or more fixtures using a DMX-512 controller or to run synchronized shows of two or more fixtures set to a master/slave operating mode. The combined number of channels required by all the fixtures on a serial data link determines the number of fixtures the data link can support.

Important: Fixtures on a serial data link must be daisy-chained in a single line. To comply with the EIA-485 standard, no more than 30 devices should be connected on one data link. Connecting more than 30 fixtures on one serial data link without the use of a DMX optically isolated splitter may result in deterioration of the digital DMX signal.

Maximum recommended DMX data link distance: 100 meters
 Maximum recommended number of fixtures on a DMX data link: 30 fixtures
 Maximum recommended number of fixtures on a power link: 8 @ 110 V
 Maximum recommended number of fixtures on a power link: 19 @ 240 V



Data Cabling

To link fixtures together, you must obtain data cables. You can purchase DAP Audio certified DMX cables directly from a dealer/distributor or construct your own cable. If you choose to create your own cable, please use data-grade cables that can carry a high quality signal and are less prone to electromagnetic interference.

DAP Audio Certified DMX Data Cables

- DAP Audio Basic microphone cable for allround use. bal. XLR/M 3 p. > XLR/F 3 p.
Ordercode FL01150 (1,5m.), FL013 (3m.), FL016 (6m.), FL0110 (10m.), FL0115 (15m.), FL0120 (20m.).
- DAP Audio cable for the demanding user with exceptional audio-qualities and connector made by Neutrik®. **Ordercode** FL71150 (1,5m.), FL713 (3m.), FL716 (6m.), FL7110 (10m.).

The Power Spot 9 Q6 Tour can be operated with a DMX controller in **control mode** or without the DMX controller in **stand-alone mode**.

Control Panel

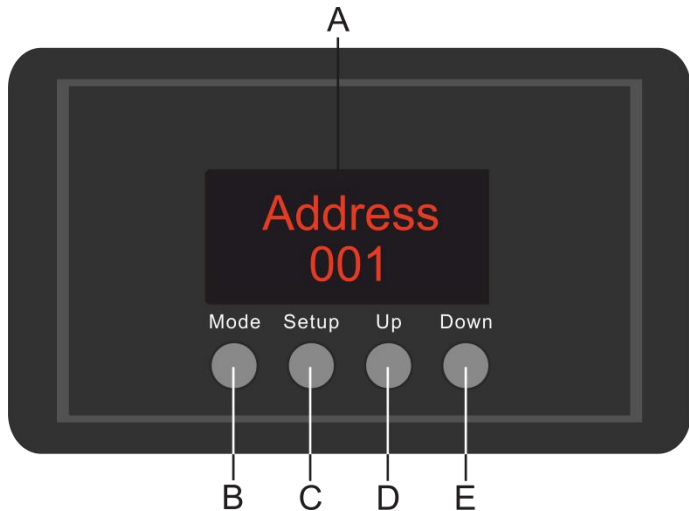

- A) LCD display
- B) MODE button
- C) SETUP button
- D) UP button
- E) DOWN button

Fig. 05

Control Mode

The fixtures are individually addressed on a data-link and connected to the controller. The fixtures respond to the DMX signal from the controller. (When you select the DMX address and save it, the controller will display the saved DMX address, next time.)

DMX Addressing

The control panel on the front side of the base allows you to assign DMX fixture addresses, which is the first channel with which the Power Spot will respond to the controller.

Please note, when you use the controller, the unit has **10** channels.

When using multiple Power Spots, make sure you set the DMX addresses right.

Therefore, the DMX address of the first Power Spot should be **1(001)**; the DMX address of the second Power Spot should be **1+10=11 (011)**; the DMX address of the third Power Spot should be **11+10=21 (021)**, etc. Please, be sure that you do not have any overlapping channels in order to control each Power Spot correctly. If two or more Power Spots are addressed similarly, they will work similarly.

Controlling:

After having addressed all Power Spot fixtures, you may now start operating these via your lighting controller.

Note: After switching on, the Power Spot will automatically detect whether DMX 512 data is received or not.

If there is no data received at the DMX-input, the "LED" on the control panel will not flash.

If not, the problem may be:

- The XLR cable from the controller is not connected with the input of the Power Spot 9 Q6 Tour.
- The controller is switched off or defective, the cable or connector is defective, or the signal wires are swapped in the input connector.

Note: It is necessary to insert an XLR termination plug (with 120 Ohm) in the last fixture in order to ensure proper transmission on the DMX data link.

Display Off after 10 seconds

When no button is pressed for 10 seconds, the display will turn off.







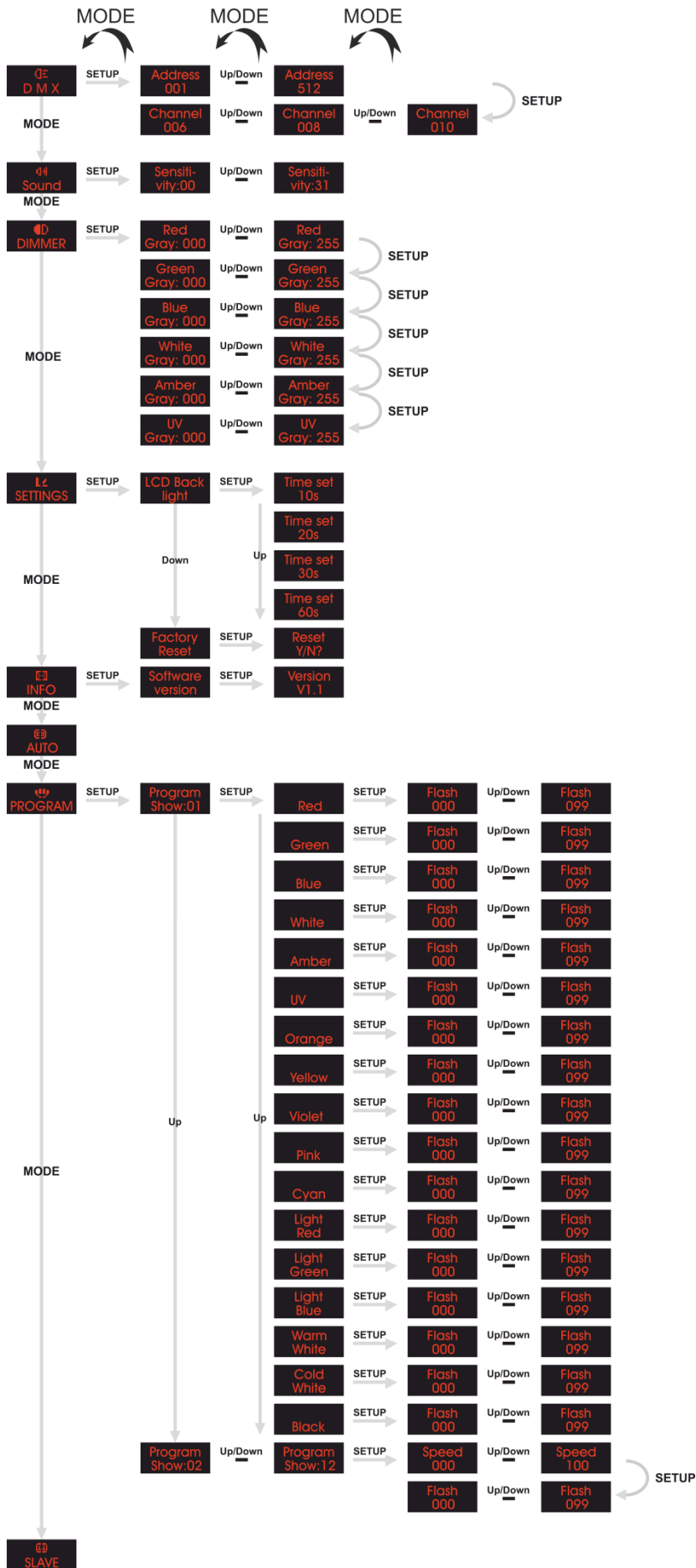

To light up the display, you have to press the MODE, SETUP, UP or DOWN button.

Once you have pressed the button, the display will light up.

Menu Overview







Main Menu Options

	DMX-512 Mode
	Sound-controlled Mode
	Manual Mode (Static Color Mode)
	Settings
	Info
	Auto Mode
	Built-in programs
	Master/Slave Mode

The Power Spot 9 Q6 Tour will show its version number at start-up! 

1. DMX Addressing





In this menu you can set the DMX address.

- 01) Press the **MODE** button until the display shows .
- 02) Press the **SETUP** button to open this menu.
- 03) Press the **UP/DOWN** buttons to select the DMX starting address from   .
- 04) Press the **SETUP** button to set 3 different DMX modes. Use the **UP/DOWN** buttons to choose between 6, 8 or 10 Channels.



2. Sound-controlled

In this menu you can you can set the audio sensitivity.

- 01) Press the **MODE** button until the display shows .
- 02) Press the **SETUP** button to open this menu and set the sensitivity of the Power Spot 9 Q6 Tour.
- 03) Press the **UP/DOWN** buttons to set the required sensitivity from   .
- 04) Turn on the music and the Power Spot 9 Q6 Tour will react to the beat of the music

3. Manual Mode (Static Color Mode)

In this menu you can you can manually set a desired color.

- 01) Press the **MODE** button until the display shows .
- 02) Press the **SETUP** button to open the menu.
- 03) Repeatedly press the **SETUP** button to toggle between the following color settings:

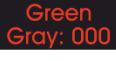
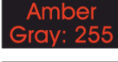
	Up/Down 		Set the value of the red LEDs (000-255)
	Up/Down 		Set the value of the green LEDs (000-255)
	Up/Down 		Set the value of the blue LEDs (000-255)
	Up/Down 		Set the value of the white LEDs (000-255)
	Up/Down 		Set the value of the amber LEDs (000-255)
	Up/Down 		Set the value of the UV LEDs (000-255)

- 04) Press the **UP/DOWN** buttons to adjust the intensity of each of the 6-color LEDs. The adjustment range is between 0-255, from low to high intensity. You can combine Red, Green, Blue, White, Amber and UV to create an infinite range of colors.

4. Settings

In this menu you can manually set a few settings.

- 01) Press the **MODE** button until the display shows .
- 02) Press the **SETUP** button to open this menu.



The Power Spot 9 has 2 different setting modes.



4.1. LCD Backlight

- 01) Press the **SETUP** button to open menu .
- 02) Press the **UP/DOWN** buttons to select the desired LCD backlight time.



The Power Spot 9 has 4 different LCD backlight time settings.

4.2. Factory Reset



- 01) Press the **SETUP** button to open menu .
- 02) Press the **SETUP** button to open menu .
- 03) Press the **UP/DOWN** buttons to confirm the reset.

Reset possibility 2:

To reset the device to its factory default settings, press and hold down the **MODE** and **SETUP** buttons for a few seconds.

5. Info

In this menu you can view the version number of your Power Spot 9.

- 01) Press the **MODE** button until the display shows .
- 02) Press **SETUP** to enter the Software Version Menu .
- 03) Press **SETUP** to show the version number .

6. Auto Mode

In this menu you can set the Power Spot 9 to the auto run program.

- 01) Press the **MODE** button on the device, until the display shows . The device will now run all the available built-in programs in a sequence. It is not possible to adjust any settings in Auto mode.

7. Built-in programs

In this menu you can you can set the built-in programs.

01) Press the **MODE** button until the display shows **PROGRAM**.

02) Press the **SETUP** button to open this menu.



03) Press the **UP/DOWN** buttons to scroll through the 12 built-in programs.

04) Press the **SETUP** button to open menu **Program Show:01**.

05) Press the **UP/DOWN** buttons to choose a color setting.

06) Press the **SETUP** button to change the flash frequency of every color from **Flash 000** **Up/Down** **Flash 099**. This does not apply for the color setting **Black**.

07) When you select **Program Show:02** **Up/Down** **Program Show:12**, press the **UP/DOWN** buttons to switch between the built-in programs.

08) Choose 2 different sub menus.

Speed 000 **Up/Down** **Speed 100** Speed from 000-100.

Flash 000 **Up/Down** **Flash 099** Flash Frequency from 000-099.

09) Press the **SETUP** button to open one of these menus or to switch between both menus.

10) Press the **UP/DOWN** buttons to change the speed from **Speed 000** **Up/Down** **Speed 100**.

11) Press the **UP/DOWN** buttons to change the flash frequency from **Flash 000** **Up/Down** **Flash 099**.

8. Slave Mode

In this menu you can set slave mode.

01) Press the **MODE** button and then the **UP/DOWN** buttons, until the display shows **SLAVE**.

If the device has not been set to slave, it is automatically classified as a master device. All slave devices will follow the master movement. If the device has been set to slave, it will react the same as its master device.

DMX Channels

6 channels

Channel 1 – Red

0–255 Gradual adjustment Red, from 0–100 %

Channel 2 – Green

0–255 Gradual adjustment Green, from 0–100 %

Channel 3 – Blue

0–255 Gradual adjustment Blue, from 0–100 %

Channel 4 – White

0–255 Gradual adjustment White, from 0–100 %

Channel 5 – Amber

0–255 Gradual adjustment Amber, from 0–100 %

Channel 6 – UV

0–255 Gradual adjustment UV, from 0–100 %

8 channels

Channel 1 – Dimmer intensity

0–255 Gradual adjustment, from dark to brightest 0–100 %

Channel 2 – Red Dimmer must be open

0–255 Gradual adjustment Red, from 0–100 %

Channel 3 – Green Dimmer must be open

0–255 Gradual adjustment Green, from 0–100 %

Channel 4 – Blue Dimmer must be open

0–255 Gradual adjustment Blue, from 0–100 %

Channel 5 – White Dimmer must be open

0–255 Gradual adjustment White, from 0–100 %

Channel 6 – Amber Dimmer must be open

0–255 Gradual adjustment Amber, from 0–100 %

Channel 7 – UV

0–255 UV flash frequency, from slow to fast

Channel 8 – Strobe Dimmer and CH2, CH3, CH4, CH5, CH6 or CH7 must be open

0–255 Strobe flash frequency, from slow to fast

10 channels

Channel 1 – Dimmer intensity

0–255 Gradual adjustment, from dark to brightest 0–100 %

Channel 2 – Red Dimmer must be open

0–255 Gradual adjustment Red, from 0–100 %

Channel 3 – Green Dimmer must be open

0–255 Gradual adjustment Green, from 0–100 %

Channel 4 – Blue Dimmer must be open

0–255 Gradual adjustment Blue, from 0–100 %

Channel 5 – White Dimmer must be open

0–255 Gradual adjustment White, from 0–100 %

Channel 6 – Amber Dimmer must be open

0–255 Gradual adjustment Amber, from 0–100 %

Channel 7 – UV Dimmer must be open

0–255 Gradual adjustment UV, from 0–100 %

Channel 8 – Program Modes

0	No function
1–20	Static color mode / Program 1
21–41	Program 2
42–62	Program 3
63–83	Program 4
84–104	Program 5
105–125	Program 6
126–146	Program 7
147–167	Program 8
168–188	Program 9
189–209	Program 10
210–230	Program 11
231–251	Program 12
252–255	Sound-controlled mode

Channel 9 – Static Colors CH8 must be set between 1-20

0	Black
1–16	Red
17–33	Green
34–50	Blue
51–67	White
68–84	Amber
85–101	UV
102–118	Orange
119–135	Yellow
136–152	Violet
153–169	Pink
170–186	Cyan
187–203	Light Red
204–220	Light green

221-237	Light blue
238-254	Warm White
255	Cold White

Channel 9 – Program Speed ⚠ **CH8 must be set between 21-251** ⚠
0-255 Slow to fast

Channel 9 – Sound sensitivity ⚠ **CH8 must be set between 252-255** ⚠
0-255 Audio sensitivity from less sensitive to highly sensitive

Channel 10 – Strobe ⚠ **Dimmer and CH2, CH3, CH4, CH5, CH6 or CH7 must be open** ⚠
0 No function
1-255 Strobe flash frequency, from slow to fast

Maintenance

The operator has to make sure that safety-related and machine-technical installations are to be inspected by an expert after every year in the course of an acceptance test.

The operator has to make sure that safety-related and machine-technical installations are to be inspected by a skilled person once a year.

The following points have to be considered during the inspection:

- 01) All screws used for installing the device or parts of the device have to be tightly connected and must not be corroded.
- 02) There may not be any deformations on housings, fixations and installation spots.
- 03) Mechanically moving parts like axles, eyes and others may not show any traces of wearing.
- 04) The electric power supply cables must not show any damages or material fatigue.

The Power Spot 9 Q6 Tour requires almost no maintenance. However, you should keep the unit clean. Otherwise, the fixture's light output will be significantly reduced. Disconnect the mains power supply, and then wipe the cover with a damp cloth. Do not immerse in liquid. Wipe lens clean with glass cleaner and a soft cloth. Do not use alcohol or solvents.

The front lens will require weekly cleaning, as smoke-fluid tends to build up residues, reducing the light output very quickly.

Keep connections clean. Disconnect electric power, and then wipe the DMX and audio connections with a damp cloth. Make sure connections are thoroughly dry before linking equipment or supplying electric power.

Troubleshooting

This troubleshooting guide is meant to help solve simple problems.

If a problem occurs, carry out the steps below in sequence until a solution is found. Once the unit operates properly, do not carry out following steps.

- 01) To reset the device to its factory default settings, press and hold down the **MODE** and **SETUP** buttons for a few seconds.
- 02) The Powerspot has a thermal protection function in order to avoid problems. This will work when the temperature is too high, but also when the atmosphere temperature is too low. When a temperature error occurs, the fixture will auto enter into a self-protection state. The LCD display will show a flashing **RT ERROR**.
- 03) When the fixture is operated in a room where the temperature is too high, please reduce power, to prevent damage to the fixture.
- 04) When a DMX signal is received, the display will show **DMX IN**.

No Light

If the light effect does not operate properly, refer servicing to a technician.

Suspect three potential problem areas as: the power supply, the LEDs, the internal fuse.

- 01) Power supply. Check that the unit is plugged into an appropriate power supply.
- 02) The LEDs. Return the Power Spot to your Showtec dealer.
- 03) The internal fuse. Return the Power Spot to your Showtec dealer.
- 04) If all of the above appears to be O.K., plug the unit in again.
- 05) If you are unable to determine the cause of the problem, do not open the Power Spot, as this may damage the unit and the warranty will become void.
- 06) Return the device to your Showtec dealer.

No Response to DMX

Suspect the DMX cable or connectors, a controller malfunction, a light effect DMX card malfunction.

- 01) Check the DMX setting. Make sure that DMX addresses are correct.
- 02) Check the DMX cable: Unplug the unit; change the DMX cable; then reconnect to electrical power. Try your DMX control again.
- 03) Determine whether the controller or light effect is at fault. Does the controller operate properly with other DMX products? If not, take the controller in for repair. If so, take the DMX cable and the light effect to a qualified technician.

Problem	Probable cause(s)	Solution
One or more fixtures do not function at all	No power to the fixture	<ul style="list-style-type: none"> • Check if power is switched on and cables are plugged in
	Internal fuse blown	<ul style="list-style-type: none"> • Return the Power Spot to your Showtec dealer.
Fixtures reset correctly, but all respond erratically or not at all to the controller	The controller is not connected.	<ul style="list-style-type: none"> • Connect controller.
	3-pin XLR Out of the controller does not match XLR Out of the first fixture on the link (i.e. signal is reversed)	<ul style="list-style-type: none"> • Install a phase reversing cable between the controller and the first fixture on the link
Fixtures reset correctly, but some respond erratically or not at all to the controller	Poor data quality	<ul style="list-style-type: none"> • Check data quality. If much lower than 100 percent, the problem may be a bad data link connection, poor quality or broken cables, missing termination plug, or a defective fixture disturbing the link
	Bad data link connection	<ul style="list-style-type: none"> • Inspect connections and cables. Correct poor connections. Repair or replace damaged cables
	Data link not terminated with 120 Ohm termination plug	<ul style="list-style-type: none"> • Insert termination plug in output jack of the last fixture on the link
	Incorrect addressing of the fixtures	<ul style="list-style-type: none"> • Check address setting
	One of the fixtures is defective and disturbs data transmission on the link	<ul style="list-style-type: none"> • Bypass one fixture at a time until normal operation is restored: unplug both connectors and connect them directly together. • Have the defective fixture serviced by a qualified technician
	3-pin XLR Out on the fixtures does not match (pins 2 and 3 reversed)	<ul style="list-style-type: none"> • Install a phase-reversing cable between the fixtures or swap pin 2 and 3 in the fixture that behaves erratically
No light or lamp cuts out intermittently	Fixture is too hot	<ul style="list-style-type: none"> • Allow the fixture to cool down • Clean the fan • Turn up the air conditioning
	LEDs damaged	<ul style="list-style-type: none"> • Disconnect the fixture and return it to your dealer
	The power supply settings do not match local AC voltage and frequency	<ul style="list-style-type: none"> • Disconnect fixture. Check settings and correct if necessary

Product Specifications

Model:	Showtec Power Spot 9 Q6 Tour
Input Voltage:	100-240 V, 50/60 Hz
Power consumption:	64,1 W (full output)
DMX linking:	30 pcs
Dimensions:	264 x 113 x 294 mm (LxWxH)
Weight:	2,84 kg
Operating and Programming:	
Signal pin OUT:	Pin 1 (earth), pin 2 (-), pin 3 (+)
DMX Mode:	6, 8, 10 Channels
Signal input:	3-pin + 5-pin XLR IN
Signal output:	3-pin + 5-pin XLR OUT
Electro-mechanical effects:	
LED Quantity:	9 x 6-in-1 12W LED RGBWA-UV
Refreshrate	7,8 kHz, Flicker free (Suitable for TV Studio)
Color mixing:	RGBWA-UV
Beam angle:	18°
Dimmer:	0-100 %
Strobe:	0-20 Hz
Housing:	Die cast aluminum, powder coat finish
DMX-control:	via standard DMX-controller
On Board:	LCD display for easy setup
Control:	Built-in programs, Auto, DMX, Slave, Sound-controlled, Manual
Connections:	Blue White Power connector IN/OUT
Cooling:	100 % silent / Forced Convection
Max. ambient temperature t_a :	40 °C
Max. housing temperature t_B :	70 °C
Minimum distance:	
Minimum distance to lighted object:	0,2 m

Design and product specifications are subject to change without prior notice.



Website: www.Showtec.info
 Email: service@highlite.com

Dimensions

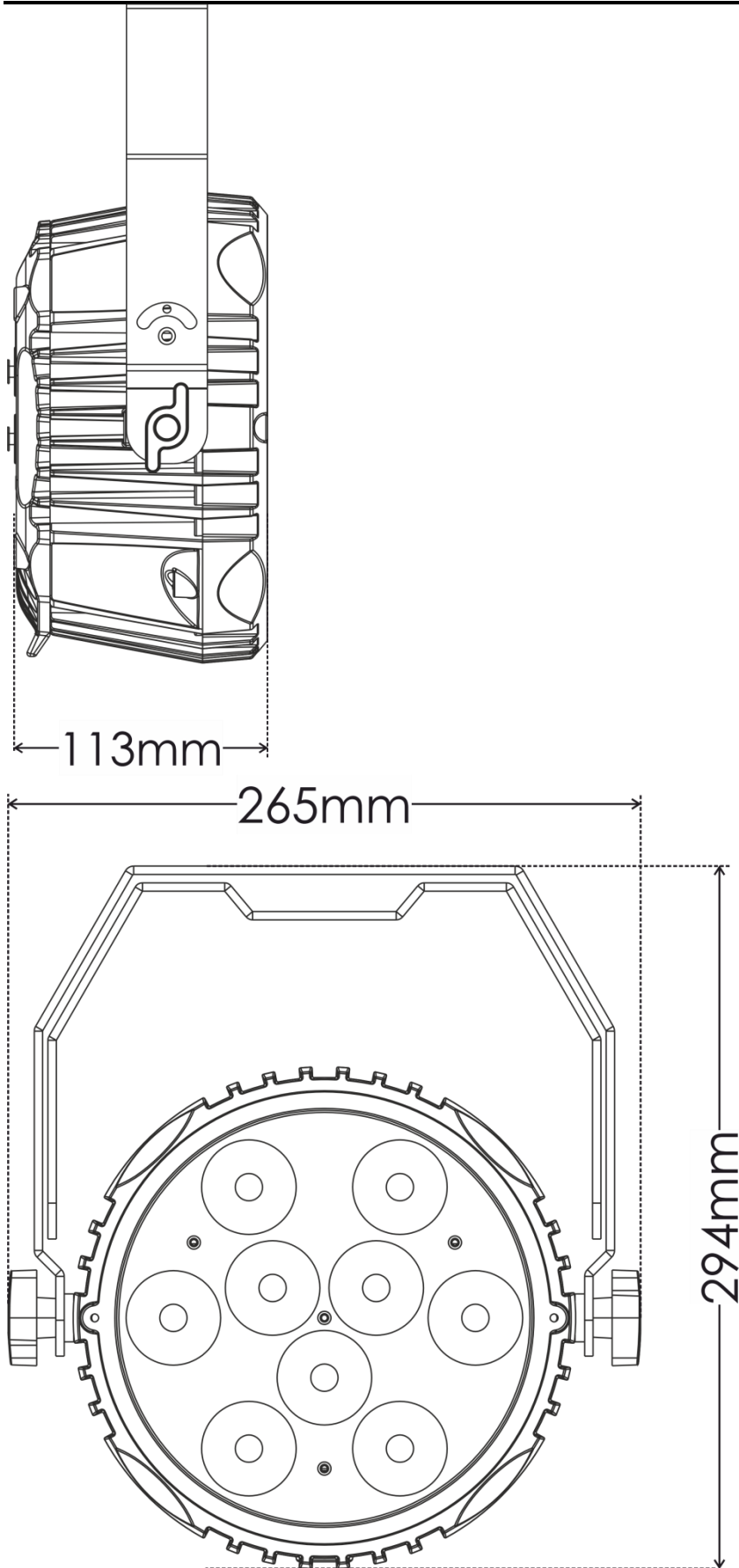



©2021 Showtec