

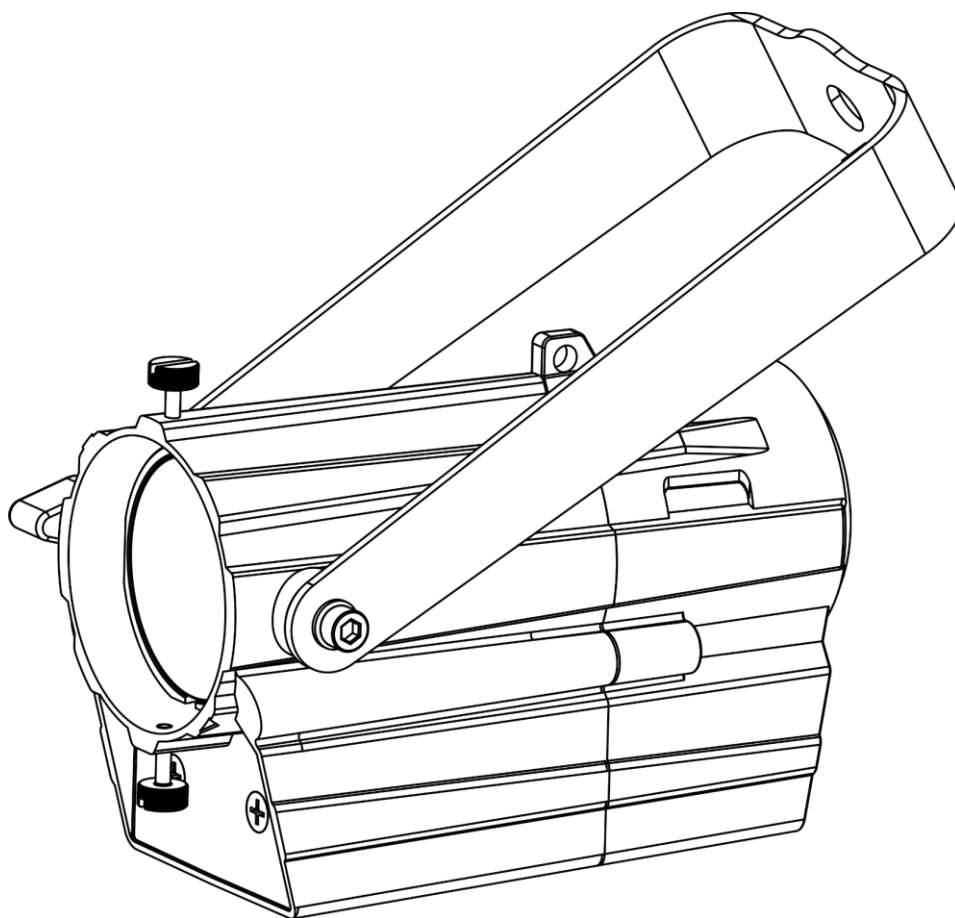

MANUAL



ENGLISH

Performer Profile Mini MKII 3200K V1

Ordercode: 33090

Table of contents

Warning2
Safety Instructions2
Operating Determinations4
Rigging4
Connection with the mains.....5
Return Procedure6
Claims.....6

Description of the device.....7
Front7
Back.....8

Installation.....8

Set Up and Operation8
Lens Locations9
Focusing the Beam9
Gobo Slot.....9
Color Frame Retaining Clip.....10
Shaping the Beam10
Rotating the Barrel.....10
Control Modes.....11
 Manual Dimmer (Control)11
 Manual Dimmer Setup11
 Multiple Performers (DMX/RDM Control)12
Fixture Linking13
Data Cabling13
DMX Channels13
 1 channel13

Cleaning.....14
Cleaning 19°, 26°, and 36° Glass Lenses14
Cleaning the Reflector14

Maintenance.....14

Troubleshooting15
No Light15
No Response to DMX.....15

Product Specifications16

Notes.....17

Warning



**For your own safety, please read this user manual carefully
before your initial start-up!**



Unpacking Instructions

Immediately upon receiving this product, carefully unpack the carton and check the contents to ensure that all parts are present, and have been received in good condition. Notify the dealer immediately and retain packing material for inspection if any parts appear damaged from shipping or the carton itself shows signs of mishandling. Save the carton and all packing materials. In the event that a fixture must be returned to the factory, it is important that the fixture be returned in the original factory box and packing.

Your shipment includes:

- Performer Profile Mini MKII 3200K with Schuko power cable (1,4 m)
- 1 x safety cable
- User manual

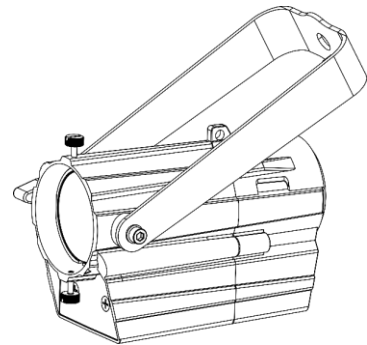

LED Expected Lifespan

LEDs gradually decline in brightness over time. HEAT is the dominant factor that leads to the acceleration of this decline. Packaged in clusters, LEDs exhibit higher operating temperatures than in ideal or singular optimum conditions. For this reason, when all color LEDs are used at their fullest intensity, life of the LEDs is significantly reduced. If improving the lifespan is of higher priority, place care in providing for lower operational temperatures. This may include climatic-environmental and the reduction of overall projection intensity.



CAUTION!

**Keep this device away from rain and moisture!
Unplug mains lead before opening the housing!**



Safety Instructions

Every person involved with the installation, operation and maintenance of this device has to:

- be qualified
- follow the instructions of this manual



**CAUTION! Be careful with your operations.
With a dangerous voltage you can suffer
a dangerous electric shock when touching the wires!**



Before the initial start-up, please make sure that there is no damage caused by transportation. Should there be any, consult your dealer and do not use the device.

To maintain perfect condition and to ensure a safe operation, it is absolutely necessary for the user to follow the safety instructions and warning notes contained in this manual.

Please consider that damages caused by manual modifications to the device are not subject to warranty.

This device contains no user-serviceable parts. Refer servicing to qualified technicians only.

IMPORTANT:

The manufacturer will not accept liability for any resulting damages caused by the non-observance of this manual or any unauthorized modification to the device.

- Never let the power cord come into contact with other cables! Handle the power cord and all connections with the mains with particular caution!
- Never remove warning or informative labels from the unit.
- Never use anything to cover the ground contact.
- Never lift the fixture holding it by the projector-head, as the mechanics may be damaged. Always hold the fixture by the transport handles.
- Never place any material over the LEDs or the lens.
- Never look directly into the light source.
- Never leave any cables lying around.
- Do not insert objects into air vents.
- Do not connect this device to a dimmer pack.
- Do not switch the device on and off in short intervals, as this will reduce the device's life.
- Do not touch the device's housing bare-handed during its operation (housing becomes very hot). Allow the fixture to cool for at least 5 minutes before handling.
- Do not shake the device. Avoid brute force when installing or operating the device.
- Only use the device indoors, avoid contact with water or other liquids.
- Only operate the fixture after having checked if the housing is firmly closed and all screws are tightly fastened.
- Only operate the device after having familiarized with its functions.
- Avoid flames and do not put close to flammable liquids or gases.
- Always keep the case closed while operating.
- Always allow a free air space of at least 50 cm around the unit for ventilation.
- Always disconnect power from the mains, when device is not used or before cleaning! Only handle the power cord holding it by the plug. Never pull out the plug by tugging the power cord.
- Make sure that the device is not exposed to extreme heat, moisture or dust.
- Make sure that the available voltage is not higher than stated on the rear panel.
- Make sure that the power cord is never crimped or damaged. Check the device and the power cord from time to time.
- If the lens is obviously damaged, it has to be replaced.
- If device was dropped or struck, disconnect mains power supply immediately. Have a qualified engineer inspect for safety before operating.
- If the device has been exposed to drastic temperature fluctuation (e.g. after transportation), do not switch it on immediately. The arising condensation water might damage your device. Leave the device switched off until it has reached room temperature.
- If your Showtec device fails to work properly, discontinue the use immediately. Pack the unit securely (preferably in the original packing material), and return it to your Showtec dealer for service.
- For adult use only. The fixture must be installed beyond the reach of children. Never leave the unit running unattended.
- Never attempt to bypass the thermostatic switch or fuses.
- The user is responsible for correct positioning and operating of the Performer. The manufacturer will not accept liability for damages caused by the misuse or incorrect installation of this device.
- This device falls under protection class I. Therefore it is essential to connect the yellow/green conductor to earth.
- Repairs, servicing and electric connection must be carried out by a qualified technician.
- WARRANTY: Till one year after date of purchase.



CAUTION! Eyedamages!!!
Avoid looking directly into the lightsource!!!
(meant especially for epileptics)!!!



Operating Determinations

- This device is not designed for permanent operation. Consistent operation breaks will ensure that the device will serve you for a long time without defects.
- The minimum distance between light output and the illuminated surface must be bigger than 50 cm.
- To eliminate wear and improve lifespan, during periods of non-use, completely disconnect from power via breaker or by unplugging.
- The maximum ambient temperature $t_a = 40\text{ °C}$ must never be exceeded.
- The relative humidity must not exceed 50 % with an ambient temperature of 40 °C .
- If this device is operated in any other way than the one described in this manual, the product may suffer damages and the warranty becomes void.
- Any other operation may lead to dangers like short-circuit, burns, electric shock, crash, etc.

You endanger your own safety and the safety of others!

Rigging

Please follow the European and national guidelines concerning rigging, trussing and all other safety issues.

Do not attempt the installation yourself !

Always let the installation be carried out by an authorized dealer !

Procedure:

- If the Performer is lowered from the ceiling or high joists, professional trussing systems have to be used.
- Use a clamp to mount the Performer, with the mounting bracket, to the trussing system.
- The Performer must never be fixed swinging freely in the room.
- The installation must always be secured with a safety attachment, e.g. an appropriate safety net or safety cable.
- When rigging, derigging or servicing the Performer, always make sure, that the area below the installation site is secured and that there are not any unauthorized people around.

Improper installation can cause serious injuries and/or damage of property!

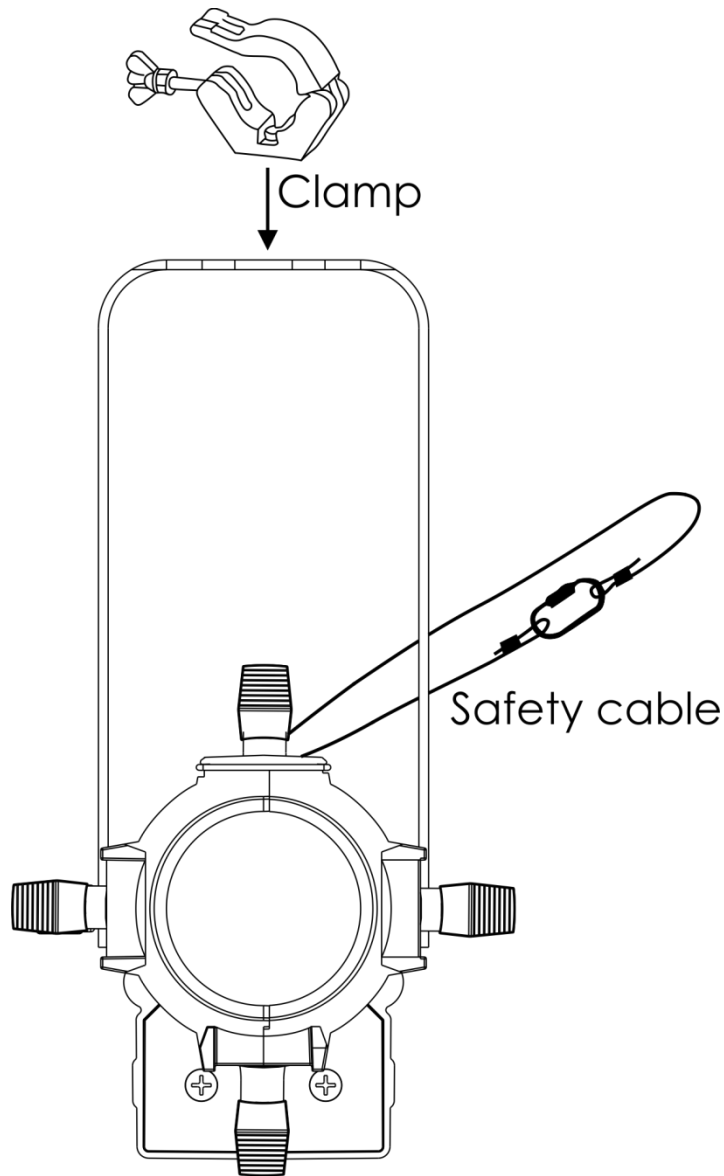

The Performer can be placed on a flat stage floor or mounted to any kind of truss with a clamp.

Connection with the mains

Connect the device to the mains with the power-plug.
Always check if the right color cable is connected to the right place.

International	EU Cable	UK Cable	US Cable	Pin
L	BROWN	RED	YELLOW/COPPER	PHASE
N	BLUE	BLACK	SILVER	NEUTRAL
⊕	YELLOW/GREEN	GREEN	GREEN	PROTECTIVE GROUND

Make sure that the device is always properly connected to the earth!

Improper installation can cause serious injuries and/or damage of property!



Return Procedure

Returned merchandise must be sent prepaid and in the original packing, call tags will not be issued. Package must be clearly labeled with a Return Authorization Number (RMA number). Products returned without an RMA number will be refused. Highlite will not accept the returned goods or any responsibility. Call Highlite 0031-455667723 or mail offersales@highlite.com and request an RMA prior to shipping the fixture. Be prepared to provide the model number, serial number and a brief description of the cause for the return. Be sure to properly pack fixture, any shipping damage resulting from inadequate packaging is the customer's responsibility. Highlite reserves the right to use its own discretion to repair or replace product(s). As a suggestion, proper UPS packing or double-boxing is always a safe method to use.

Note: If you are given an RMA number, please include the following information on a piece of paper inside the box:

- 01) Your name
- 02) Your address
- 03) Your phone number
- 04) A brief description of the symptoms

Claims

The client has the obligation to check the delivered goods immediately upon delivery for any shortcomings and/or visible defects, or perform this check after our announcement that the goods are at their disposal. Damage incurred in shipping is the responsibility of the shipper; therefore the damage must be reported to the carrier upon receipt of merchandise.

It is the customer's responsibility to report and submit claims with the shipper in the event that a fixture is damaged due to shipping. Transportation damage has to be reported to us within one day after receipt of the delivery.

Any return shipment has to be made post-paid at all times. Return shipments must be accompanied with a letter defining the reason for return shipment. Non-prepaid return shipments will be refused, unless agreed otherwise in writing.

Complaints against us must be prepared in writing or sent by fax within 10 working days after receipt of the invoice. After this period complaints will not be handled anymore.

Complaints will only then be considered if the client has so far complied with all parts of the agreement, regardless of the agreement from which the obligation is resulting.

Description of the device

Features

The Showtec Performer Profile Mini MKII 3200K is a compact theater spotlight fixture with high output.

- Input voltage: 110–240 V AC, 50/60 Hz
- Power consumption: 25 W
- Drive current: 0,5 A
- Light source: 1 x 30 W COB
- Lux @ 1 m: 15000 (19°)
- Color rendering: >90Ra
- Color temperature: 3200K
- Dimmer: Manual, DMX/RDM
- Beam angle: 19° > 36° fixed and zoom
- Connections: Schuko power cable, 3-pin DMX signal connector IN/OUT
- Mounting: Portable/track-mount
- Housing: Die-cast aluminum
- Cooling: Forced convection
- Color: Black
- IP rating: IP20
- Dimensions: 150 x 106 x 225 mm (LxWxH)
- Weight: 1,3 kg

Optional accessories

[33082](#) – Lens Tube Black 19°

[33083](#) – Lens Tube Black 26°

[33084](#) – Lens Tube Black 36°

[33085](#) – Glare Shield for Performer Profile Mini

[33086](#) – Gobo Holder for Performer Profile Mini

[33087](#) – Zoom Lens for Mini Profile 19° > 36°

[33088](#) – Shutter barrel

Front

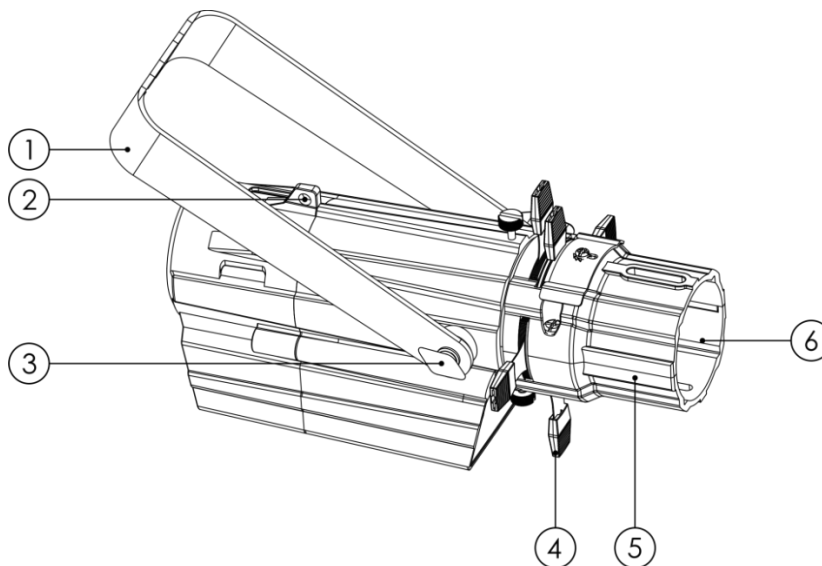

Fig. 01

- 01) Mounting bracket with inclination screw
- 02) Safety eye
- 03) Adjustment screw
- 04) Shutter (not included)
- 05) Shutter barrel (not included)
- 06) 1 x 30 W COB

Back

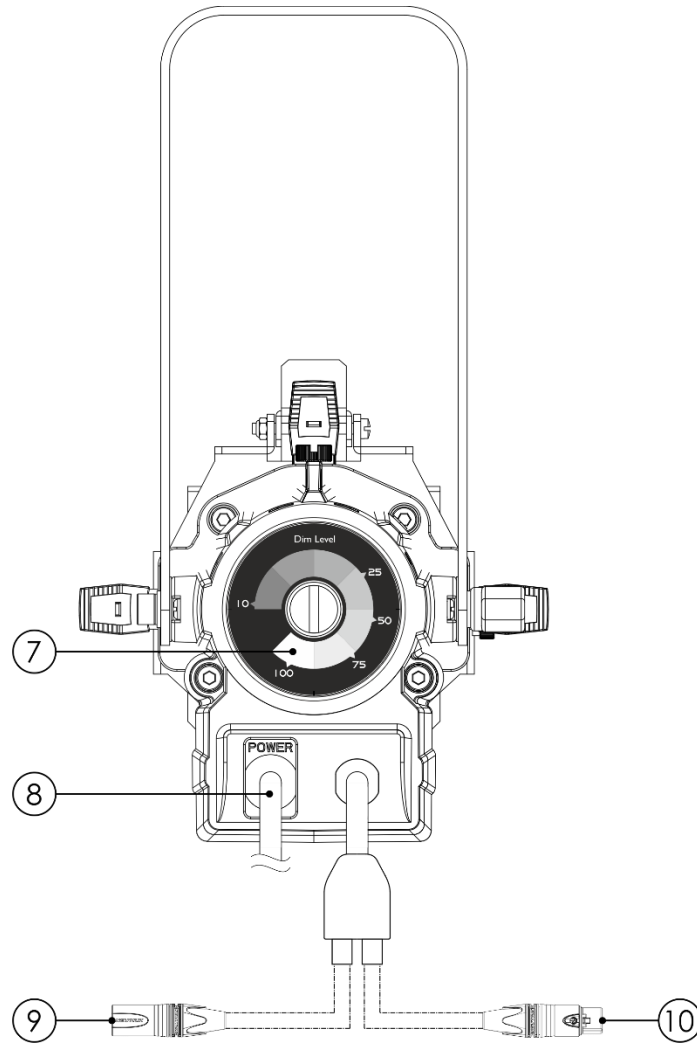

Fig. 02

- 07) Manual dimmer control
- 08) Schuko power cable (1,4 m)
- 09) 3-pin DMX signal connector IN
- 10) 3-pin DMX signal connector OUT

Installation

Remove all packing materials from the Performer Profile Mini MKII 3200K. Check if all foam and plastic padding is removed. Connect all cables.

Do not supply power before the whole system is set up and connected properly.

Always disconnect from electric mains power supply before cleaning or servicing.

Damages caused by non-observance are not subject to warranty.

Set Up and Operation

Follow the directions below, as they pertain to your preferred operation mode.

Before plugging the unit in, always make sure that the power supply matches the product specification voltage. Do not attempt to operate a 110V specification product on 230V power, or vice versa.

Connect the device to the main power supply.

Lens Locations

The different lenses used in the Performer are not interchangeable. When installing a new tube lens, refer to the illustration below for proper placement.

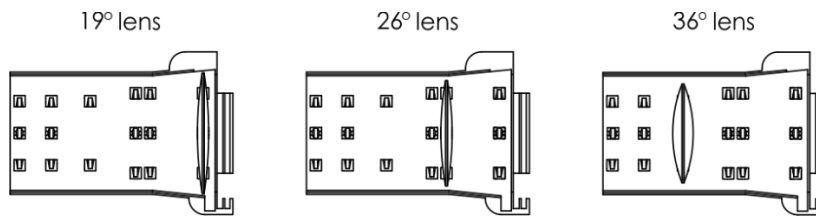

Fig. 03

Focusing the Beam

- 01) Loosen the beam focus controls located under the barrel (Fig. 04).
- 02) Slide the lens tube forwards or backwards to achieve the desired beam edge.
- 03) Once the fixture is focused, tighten the beam focus controls.

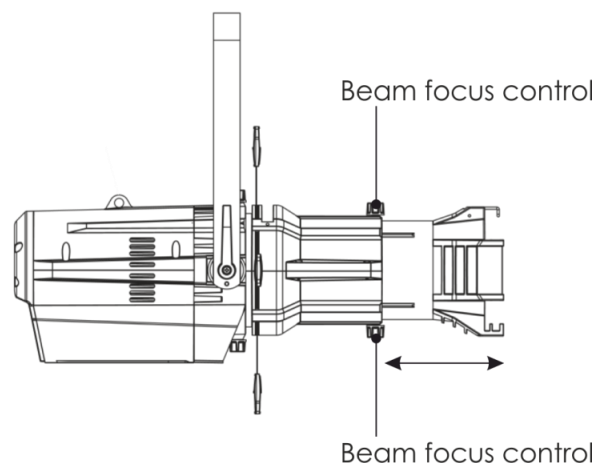

Fig. 04

Gobo Slot

The gobo slot is located on the top of the barrel and is supposed to accommodate the gobo holder (33086). When the slot is not in use, a small sheet metal cover, secured with a screw, prevents light leakage (Fig. 05).

- 01) Use a screwdriver to loosen the screw on the gobo slot cover. Do not remove the screw.
- 02) Slide the cover completely forwards to expose the slot.
- 03) Insert the gobo holder.
- 04) Slide the slot cover back towards the shutters, until it meets the gobo holder's handle. Leave enough space to move the handle.
- 05) Secure the slot cover by tightening the screw.

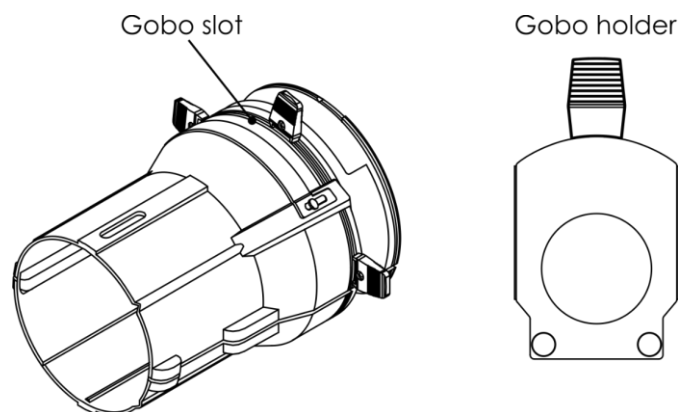

Fig. 05

Color Frame Retaining Clip

The color frame holder is equipped with a spring-loaded retaining clip. This prevents color frames and accessories from falling out (Fig. 06).



Make sure that all color frame accessories are locked in position with the retaining clip before hanging the Performer.



- 01) Release the retaining clip by pushing it sideways, until it opens.
- 02) Insert the color frame(s).
- 03) Lock the retaining clip by pushing it to the initial position, until it is secured.

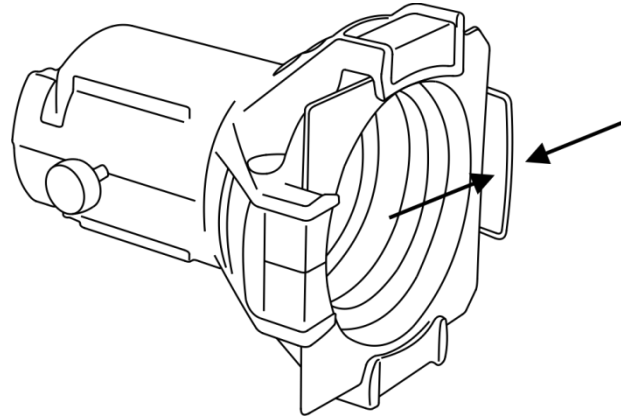

Fig. 06

Shaping the Beam

You may shape the beam with the shutters, a gobo holder or by rotating the barrel.

Rotating the Barrel

- 01) Loosen the barrel rotation control. It can be found directly behind the shutters on the bottom side of the reflector housing (Fig. 07). **Do not remove the barrel rotation control.**
- 02) Rotate the barrel to the desired position.
- 03) Tighten the barrel's rotation control to lock it in position.

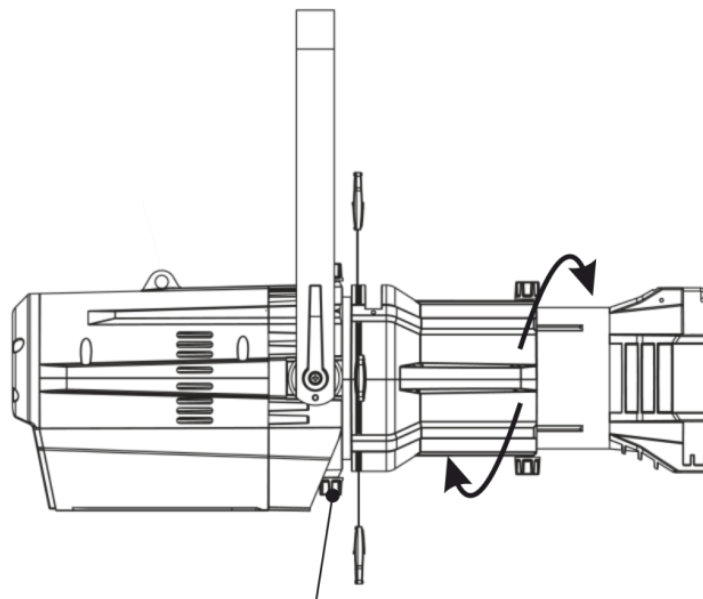

Barrel rotation control

Fig. 07

Control Modes

- There are 2 modes:
- Manual Dimmer
 - DMX-512/RDM

Manual Dimmer (Control)

- 01) Fasten the effect light to a firm trussing. Leave at least 0,5 meter on all sides for air circulation.
- 02) Always use a safety cable (ordercode 70140 / 70141).
- 03) Plug the end of the electric mains power cord into a proper electric power supply socket.
- 04) Turn the manual dimmer control **(07)** on the Performer to set the brightness. The adjustment range is between 10–100, from dark to brightest.

Manual Dimmer Setup

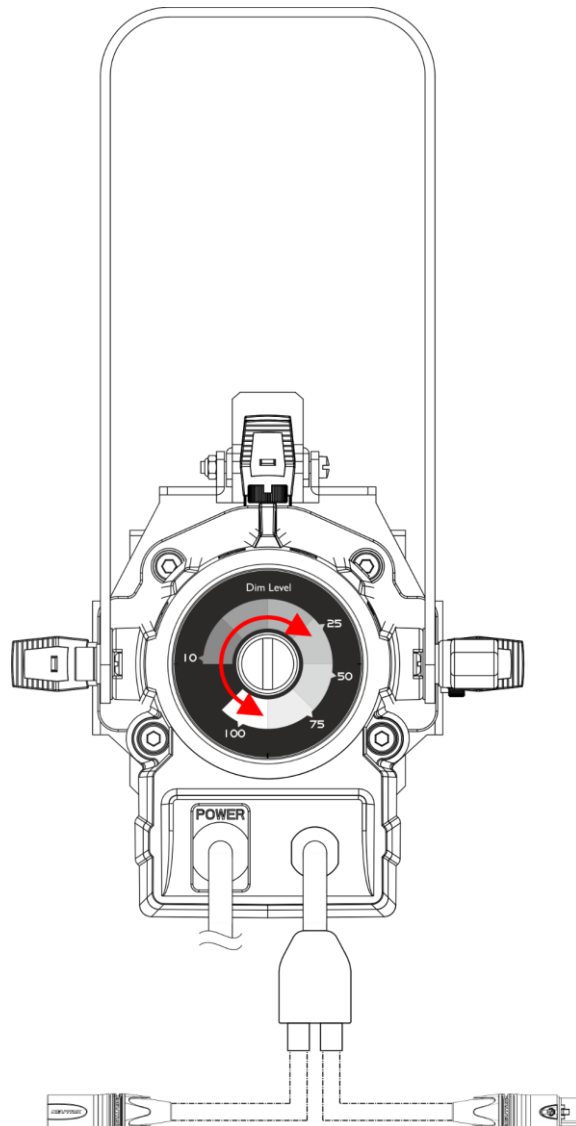

Fig. 08



Manual mode will be active **ONLY** if the Performer **DOES NOT** receive any DMX signals.



Multiple Performers (DMX/RDM Control)

- 01) Fasten the effect light to a firm trussing. Leave at least 0,5 meter on all sides for air circulation.
- 02) Always use a safety cable (ordercode 70140 / 70141).
- 03) Use a 3-pin XLR cable to connect the Performers and other devices.

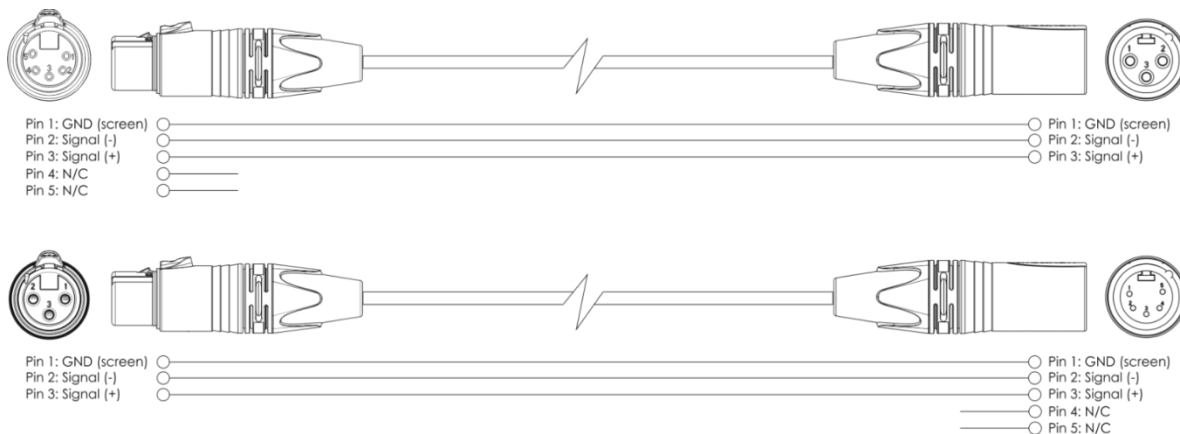

- 04) Link the units as shown in fig. 09. Connect the first unit's DMX "out" socket with the second unit's "in" socket, using a DMX signal cable. Repeat this process to link the second, third and fourth units.
- 05) Supply electric power: Plug the mains power cords into proper electric power supply sockets, starting with the first unit. Do not supply power before the whole system is set up and connected properly.

Multiple Performers DMX/RDM Setup

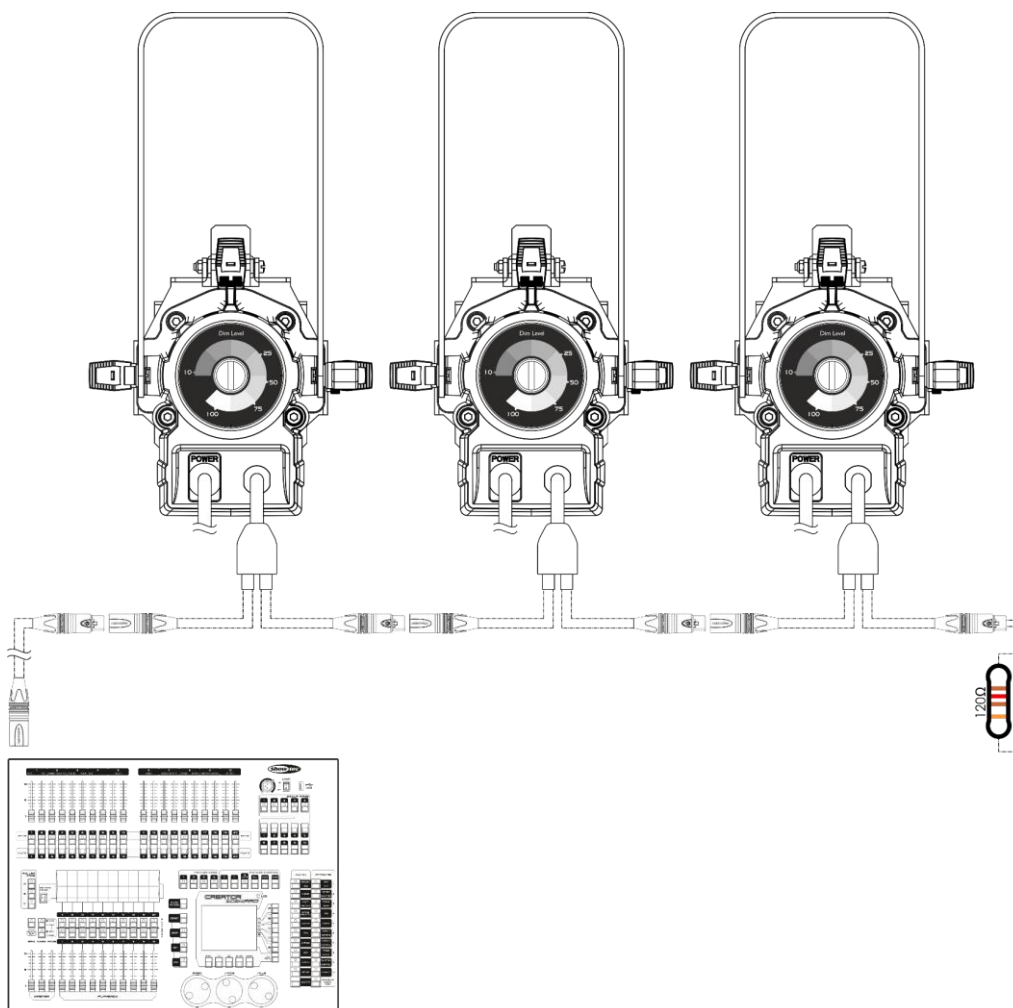

Note: Link all cables before connecting electric power

Fig. 09

Fixture Linking

You will need a serial data link to run light shows of one or more fixtures using a DMX-512 controller or to run synchronized shows of two or more fixtures set to a master/slave operating mode. The combined number of channels required by all the fixtures on a serial data link determines the number of fixtures the data link can support.

Important: Fixtures on a serial data link must be daisy-chained in a single line. To comply with the EIA-485 standard, no more than 30 devices should be connected on one data link. Connecting more than 30 fixtures on one serial data link without the use of a DMX optically isolated splitter may result in deterioration of the digital DMX signal.

 Maximum recommended DMX data link distance: 100 meters
Maximum recommended number of fixtures on a DMX data link: 30 fixtures
Maximum recommended number of fixtures on a power link @ 110V: 70 fixtures
Maximum recommended number of fixtures on a power link @ 230V: 145 fixtures

Data Cabling

To link fixtures together, you must obtain data cables. You can purchase DAP Audio certified DMX cables directly from a dealer/distributor or construct your own cable. If you choose to create your own cable, please use data-grade cables that can carry a high quality signal and are less prone to electromagnetic interference.

DAP Audio DMX Data Cables

- DAP Audio Basic microphone cable for allround use. bal. XLR/M 3-pin > XLR/F 3-pin. **Ordercode** FL01150 (1,5 m), FL013 (3 m), FL016 (6 m), FL0110 (10 m), FL0115 (15 m), FL0120 (20 m).
- DAP Audio X-type data cable XLR/M 3-pin > XLR/F 3-pin. **Ordercode** FLX0175 (0,75 m), FLX01150 (1,5 m), FLX013 (3 m), FLX016 (6 m), FLX0110 (10 m).
- DAP Audio cable for the demanding user with exceptional audio-qualities and connector made by Neutrik®. **Ordercode** FL71150 (1,5 m), FL713 (3 m), FL716 (6 m), FL7110 (10 m).
- DAP Audio cable for the demanding user with exceptional audio-qualities and connector made by Neutrik®. **Ordercode** FL7275 (0,75 m), FL72150 (1,5 m), FL723 (3 m), FL726 (6 m), FL7210 (10 m).
- DAP Audio 110 Ohm cable with digital signal transmission. **Ordercode** FL0975 (0,75 m), FL09150 (1,5 m), FL093 (3 m), FL096 (6 m), FL0910 (10 m), FL0915 (15 m), FL0920 (20 m).
- DAP Audio data cable FL08 DMX/AES-EBU, XLR/M 5-pin > XLR/F 5-pin. **Ordercode** FL08150 (1,5 m), FL083 (3 m), FL086 (6 m), FL0810 (10 m), FL0820 (20 m).
- DAP Audio DMX adapter: 5-pin/3-pin. **Ordercode** FLA29.
- DAP Audio DMX adapter: 3-pin/5-pin. **Ordercode** FLA30.
- DAP Audio DMX Terminator 3-pin. **Ordercode** FLA42.
- DAP Audio DMX Terminator 5-pin. **Ordercode** FLA43.

DMX Channels

1 channel

Channel 1 – Dimmer intensity

0–255 Gradual adjustment, from dark to brightest 0–100 %

Cleaning

Please follow the next recommendations when cleaning and inspecting lenses and reflectors:

Do not use glass or window type cleaners on lenses (glass or polymer) or reflectors.

Do not use abrasive materials such as steel wool.

Replace lenses if they contain visible damage (cracks or deep scratches) which that may impair their effectiveness.

Cleaning 19°, 26°, and 36° Glass Lenses

- 01) Remove the beam focus controls at the bottom of the barrel. Remove the lens tube from the barrel.
- 02) Dampen a clean lint-free cloth with vinegar or household ammonia. You may also use water, but it will leave spots that can be removed by gently polishing the lens with a clean and dry cloth.
- 03) Starting from the center, gently wipe the lens.
- 04) Slide the lens tube back into the barrel with the color frame-retaining clip on top. Replace the beam focus controls.

Cleaning the Reflector



Unplug the fixture before attempting to clean the reflector. To quickly clean the reflector, remove the lens tube and clean the dust from the reflector with a blast of oil-free air. You may also wipe the reflector with a clean lint-free cloth. If either method is not sufficient, follow the instructions below. You will need a screwdriver to complete this procedure.



- 01) Remove the barrel rotation controls located at the bottom of the barrel. Use a screwdriver to remove the retainer bolt located on top of the reflector housing.
- 02) Rotate the barrel by 45° in either direction. Carefully remove the barrel from the reflector housing.
- 03) Dampen a clean lint-free cloth with alcohol or distilled water (alcohol is recommended).
- 04) Gently wipe the reflector.
- 05) Insert the barrel into the reflector housing with the gobo slot on top (line up the triangles on both parts).
- 06) While pressing in gently, rotate the barrel by 45° clockwise until it sets into position. Then, rotate the barrel counterclockwise by 45°. The barrel should be firmly attached and the triangles should line up again.
- 07) Replace the barrel rotation controls and tighten the retainer bolt.

Maintenance

The operator has to make sure that safety-related and machine-technical installations are to be inspected by an expert after every year in the course of an acceptance test.

The operator has to make sure that safety-related and machine-technical installations are to be inspected by a skilled person once a year.

The following points have to be considered during the inspection:

- 01) All screws used for installing the device or parts of the device have to be tightly connected and must not be corroded.
- 02) There may not be any deformations on housings, fixations and installation spots.
- 03) Mechanically moving parts like axles, eyes and others may not show any traces of wearing.
- 04) The electric power supply cables must not show any damages or material fatigue.

The Performer Profile Mini MKII 3200K requires almost no maintenance. However, you should keep the unit clean.

Otherwise, the fixture's light output will be significantly reduced. Disconnect the mains power supply, and then wipe the cover with a damp cloth. Do not immerse in liquid. Wipe lens clean with glass cleaner and a soft cloth. Do not use alcohol or solvents.

The front lens will require weekly cleaning, as smoke-fluid tends to build up residues, reducing the light-output very quickly.

Please clean internal components once a year with a light brush and vacuum cleaner.

Make sure connections are thoroughly dry before linking equipment or supplying electric power.

Troubleshooting

This troubleshooting guide is meant to help solve simple problems.

If a problem occurs, carry out the steps below in sequence until a solution is found. Once the unit operates properly, do not carry out following steps.

No Light

If the light effect does not operate properly, refer servicing to a technician.

Suspect two potential problem areas as: the power supply and the LEDs.

- 01) Power supply. Check if the unit is plugged into an appropriate power supply.
- 02) The LEDs. Return the Performer to your Showtec dealer.
- 03) If both appear to be O.K., plug the unit in again.
- 04) If you are unable to determine the cause of the problem, do not open the Performer, as this may damage the unit and the warranty will become void.
- 05) Return the device to your Showtec dealer.

No Response to DMX

Suspect the DMX cable or connectors, a controller malfunction, a light effect DMX card malfunction.

- 01) Check the DMX setting. Make sure that DMX addresses are correct.
- 02) Check the DMX cable: Unplug the unit; change the DMX cable; then reconnect to electrical power. Try your DMX control again.
- 03) Determine whether the controller or light effect is at fault. Does the controller operate properly with other DMX products? If not, take the controller in for repair. If so, take the DMX cable and the light effect to a qualified technician.

Problem	Probable cause(s)	Solution
One or more fixtures do not function at all.	No power to the fixture.	<ul style="list-style-type: none"> • Check if power is switched on and cables are plugged in.
	Internal fuse blown.	<ul style="list-style-type: none"> • Return the device to your local Showtec dealer.
No light or LEDs cut out intermittently.	Fixture is too hot.	<ul style="list-style-type: none"> • Allow the fixture to cool down. • Turn up the air conditioning.
	LEDs damaged.	<ul style="list-style-type: none"> • Disconnect the fixture and return it to your dealer.
	The power supply settings do not match local AC voltage and frequency.	<ul style="list-style-type: none"> • Disconnect fixture. Check settings and correct if necessary.

Product Specifications

Model:	Showtec Performer Profile Mini MKII 3200K
Input voltage:	110–240 V AC, 50/60 Hz
Power consumption:	25 W
Dimensions:	150 x 106 x 225 mm (LxWxH)
Weight:	1,3 kg
Electro-mechanical effects:	
Light source:	1 x 30 W COB
Beam angle:	19° > 36° fixed and zoom
Drive current:	0,5 A
Dimmer:	Manual, DMX/RDM
Lux @ 1 m:	15000 (19°)
Color rendering:	>90Ra
Color temperature:	3200K
Housing:	Die-cast aluminum
Connections:	Schuko power cable, 3-pin DMX signal connector IN/OUT
Mounting:	Portable/track-mount
Color:	Black
IP rating:	IP20
Cooling:	Forced convection
Max. ambient temperature t_a :	40 °C
Max. housing temperature t_B :	70 °C
Minimum distance:	
Minimum distance from flammable surfaces:	0,5 m
Minimum distance to lighted object:	1 m

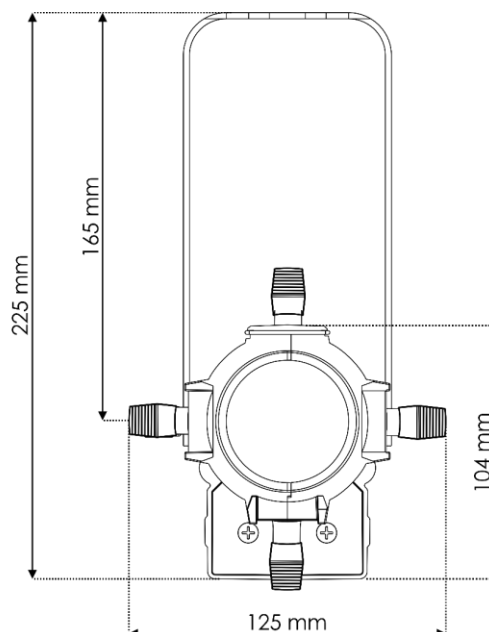
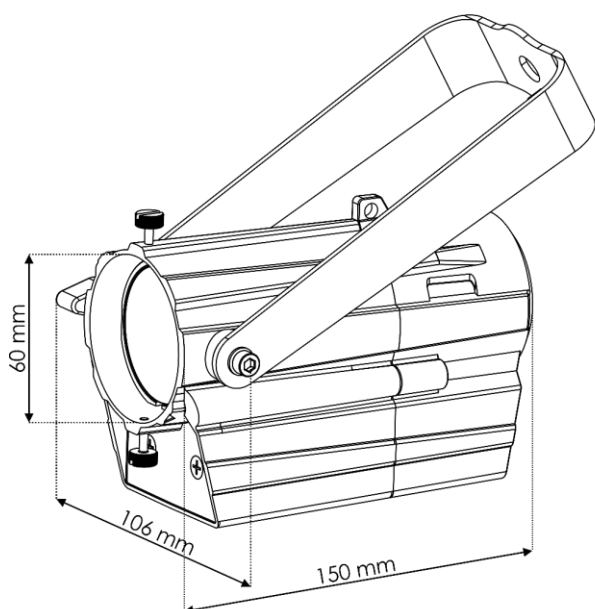

Design and product specifications are subject to change without prior notice.



Website: www.Showtec.info
 Email: service@highlite.com



©2019 Showtec